

# High Temperature Gas Reactors

Andrew C. Kadak, Ph.D.

*Professor of the Practice*

Massachusetts Institute of Technology

# MACHINE DESIGN

SEPTEMBER 27, 2001  
www.machinedesign.com



A PENTON PUBLICATION  
Periodicals  
USPS #87 Approved Foli



Kudos for best new designs, page 50



World's smartest appliances, page 71

## SPECIAL FOCUS The Future of Energy

page 77

Future Technology  
ENERGY

### Nuclear's new age

Jean M. Hoffman  
Associate Editor

It's probably understandable why some people protest the deployment of nuclear power. The safety systems on current reactors don't inspire a lot of confidence. They are characterized by numerous sensors and/or power supplies, pumps, and valves. To be unobscured, the complicated collection of components might smack of Hubble Goldberg.

Contrast this with the recently approved Westinghouse AP-600. The 600-MW pressurized light-water reactor (LWR) employs safety systems that are predominantly passive. They rely only on natural forces such as gravity, natural circulation, expansion, contraction, and condensation. All in all, the AP-600 boasts a 33% fewer pumps, 50% fewer valves, 70% less cabling, and 80% less ducting.

Pebble-bed reactors use 200,000 tennis-ball-sized fuel elements in place of conventional fuel rods.



Innovative reactor concepts may help put nuclear energy back on track.

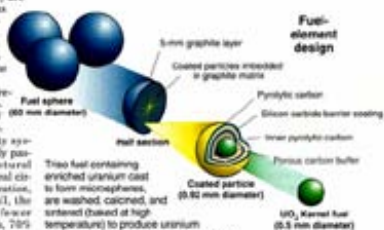

THE WORLD'S LARGEST SCIENCE & TECHNOLOGY MAGAZINE

# Poplar Science

THIS WHAT'S NEW ISSUE IS HOT

## New Life for Nuclear Power

Inside the Reactor That Won't Melt Down

Plus  
New Tech for Deep Sea Oil Drilling

SPY SATELLITE SEES THROUGH CAMOUFLAGE

HUNT FOR THE TOP DIGITAL CAMERA

Mystery Skin Cells BEST HOPE FOR BURN VICTIMS

400,000,000 \$5.99  
7,000,000 \$5.99

www.poplarscience.com

Time9

ARUNDHATI ROY ▶ "NOT BEHAVING" • DONELLA MEADOWS ▶ "DANCING WITH SYSTEMS"  
CHRIS ALEXANDER ▶ "ALIVENESS" • PERMACULTURE • ONLINE HEALTH • EVEREST • EVE ENSLER

# Whole Earth

Access to Tools, Ideas, and Practices Winter 2001

THE UNHOLY TRIUMVIRATE  
Energy, Water, Cash

LOCAL MICROPOWER  
Solar, Wind, Hydrogen,  
Biomass, Geothermal,  
Tidal, Wave

WHOLE EARTHling  
Gift List



\$6.95/\$8.50 CDN

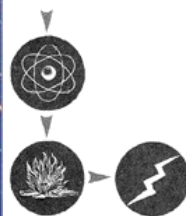

## The Politically Correct NUKE

MIT Students help design a nuclear power plant that they hope will revive the industry.

by Charles Wardell

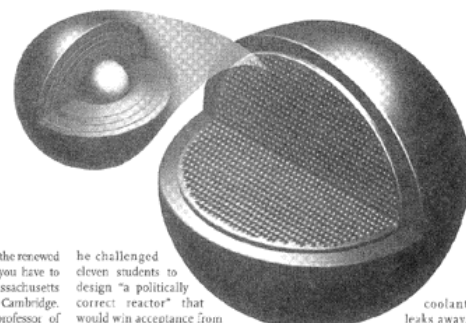

Above right: A "pebble" (about right: ball size) containing 50,000 uranium dioxide particles the size of a pencil point, each coated with several layers of graphite and a silicon carbide outer shell (inset). Though the pebbles heat to more than 1,000°C, the coatings trap the radiation inside. The particles decay within 250,000 years, but the graphite ball maintains its integrity for more than one million years.

To truly understand the renewed buzz for nuclear, you have to travel to the Massachusetts Institute of Technology in Cambridge. Here, Andrew Kadak, professor of nuclear engineering, holds two billiard-size balls that many believe represent the future of nuclear energy. The balls are the "pebbles" in something called a pebble bed reactor, a new type of plant that proponents say is safer and more efficient than current plants. It could even crank out electricity for less than a gas-fired plant, savings that would presumably be passed on to you. More important, considering our anxiety toward nuclear energy, it's immune to meltdowns. The technology could be implemented, possibly at Three Mile Island, within five years.

When Kadak, formerly vice president of the American Nuclear Society, came to MIT in 1997, nuclear power seemed doomed. So in January 1998,

he challenged eleven students to design "a politically correct reactor" that would win acceptance from regulators and the public while giving gas a run for its energy-generating money. All existing US commercial reactors are "light water" reactors. They're powered by half-inch cylindrical pellets of uranium—like cutoffs from a 1/2-inch dowel—stacked up in 14-foot-long metal rods. Hundreds of rods are lowered into a water-filled reactor core. The uranium atoms give off neutrons, some of which crash into other uranium atoms, splitting them, generating heat, and knocking free more atom-splitting neutrons—the process known as fission. The water in the core carries the heat away to drive an electric turbine.

Kadak's students rejected light-water technology for this reason: If the

coolant leaks away, the core heats up enough to melt. Instead, they found something they considered safer: a pebble bed reactor that had run for twenty-two years in Germany ("until Chernobyl" came along and Germany got out of nuclear," Kadak says). It relied on fission too, but was fueled by eight-ball-sized pebbles, and rather than water coolant, it used helium gas.

The main safety feature is the fuel itself. Each pebble consists of roughly 10,000 "microspheres" of uranium dioxide the size of a pencil point. Each is in turn coated with several layers of graphite, and a silicon carbide outer shell. While fission heats the pebbles to as much as 1,100°C, the coatings trap all radioactivity inside. Once the

# WIRED

SEPTEMBER 2008 \$7.99 (US) (NET P001123)

## RAGE AGAINST THE MACHINE

WHY **ARNOLD** (AND NOT THOSE TWO OTHER GUYS) IS THE FUTURE OF AMERICAN POLITICS  
PLUS: **MoveOn** & THE NEW WEAPONS OF MASS MOBILIZATION

HOW A **MEDIEVAL CODE CRACKER** REINVENTED THE SCIENTIFIC METHOD  
**NUCLEAR POWER**, THE NEXT GENERATION: IT'S MASS-PRODUCED, MELTDOWN-PROOF & **MADE IN CHINA**  
ARMY OF 010101: INSIDE THE **PENTAGON'S** BLEEDING EDGE **BATTLE SIMULATOR**

## LET A THOUSAND REACTORS BLOOM



Explosive growth has made the People's Republic of China the most power-hungry nation on earth. Get ready for the mass-produced, meltdown-proof future of nuclear energy.

by SPENCER REISS

Illustration by KENN BROWN and CHRIS WREN

拼装式

不會

PARALLEL UNIVERSE #10

PARALLEL UNIVERSE #10

# 拼装式反應爐

Joy-Joy Snap-together Reactor

Meltdown-proof! Safe for all ages.

# 不會熔毀！各

# Presentation Overview

- Introduction to Gas Reactors
- Pebble Bed Reactor
- Players
- International Status
- Research Needs

# Fundamentals of Technology

- Use of Brayton vs. Rankine Cycle
- High Temperature Helium Gas (900 C)
- Direct or Indirect Cycle
- Originally Used Steam Generators
- Advanced Designs Use Helium w/wo HXs
- High Efficiency (45% - 50%)
- Microsphere Coated Particle Fuel

# History of Gas Reactors in US

- Peach Bottom (40 MWe) 1967-1974
  - First Commercial (U/Thorium Cycle)
  - Generally Good Performance (75% CF)
- Fort St. Vrain ( 330 MWe) 1979-1989 (U/Th)
  - Poor Performance
  - Mechanical Problems
  - Decommissioned

# Fort St. Vrain



# Different Types of Gas Reactors

- Prismatic (Block) - General Atomics
  - Fuel Compacts in Graphite Blocks
- Pebble Bed - German Technology
  - Fuel in Billiard Ball sized spheres
- Direct Cycle
- Indirect Cycle
- Small Modular vs. Large Reactors

# GT-MHR Module General Arrangement

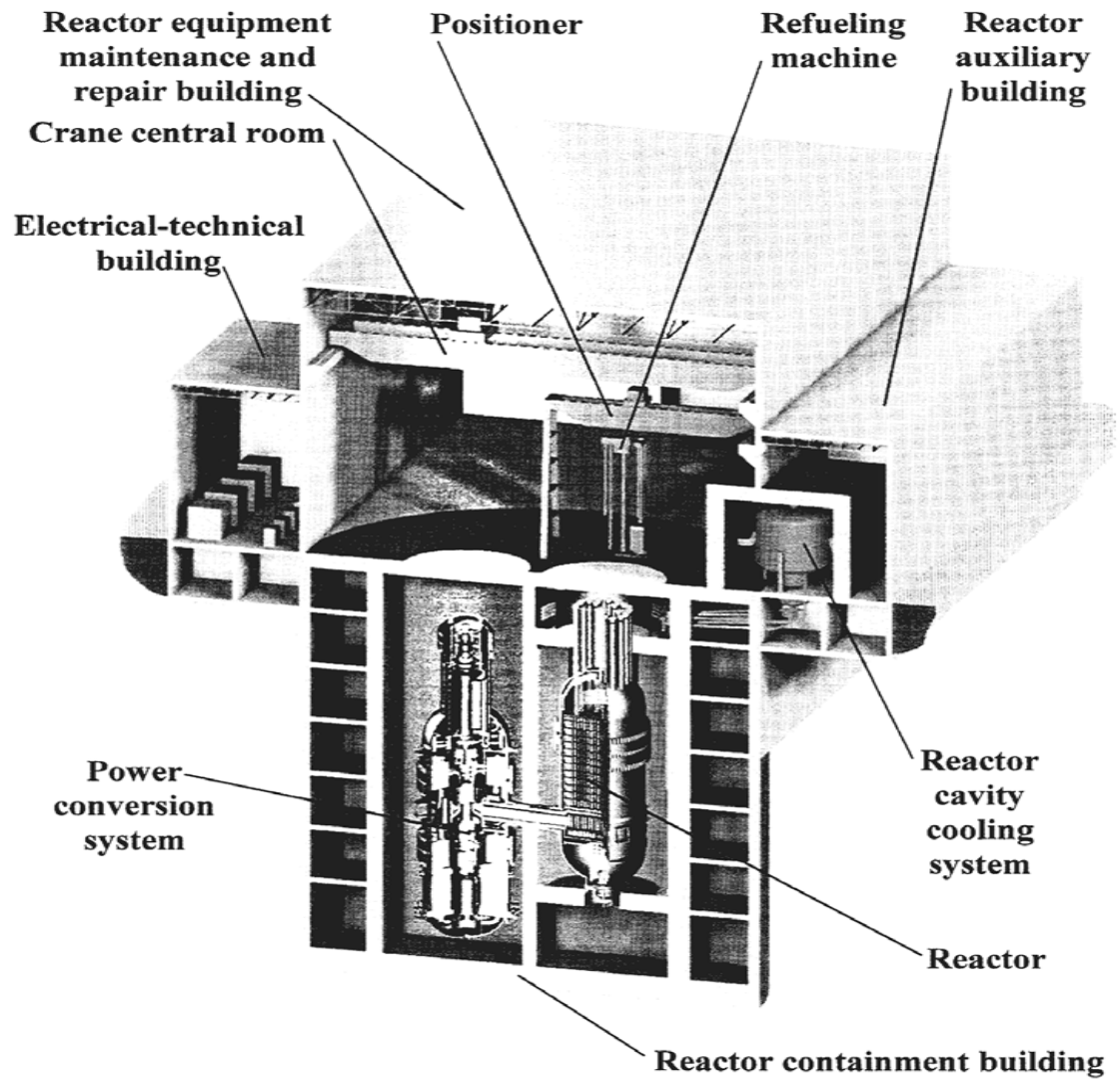

# GT-MHR Combines Meltdown-Proof Advanced Reactor and Gas Turbine

• POWER LEVEL  
600 MW(t)

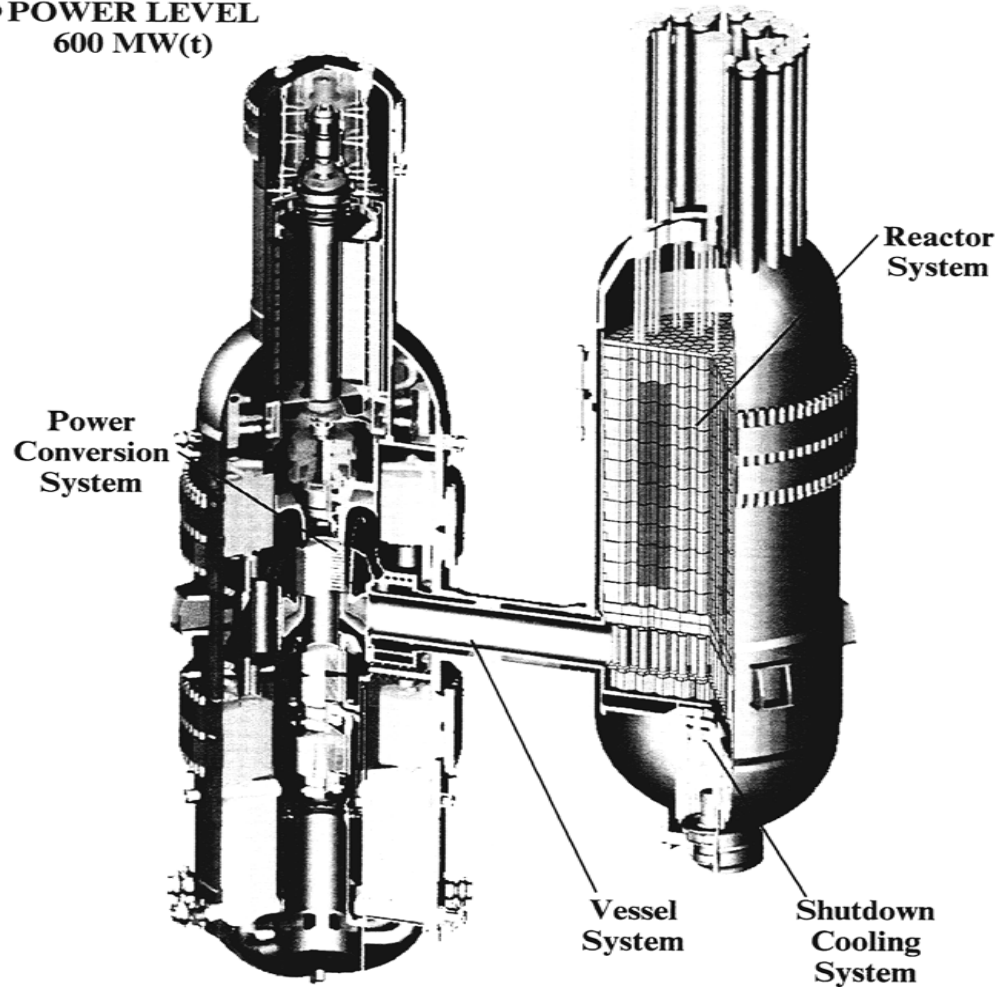

# TRISO Fuel Particle -- “Microsphere”

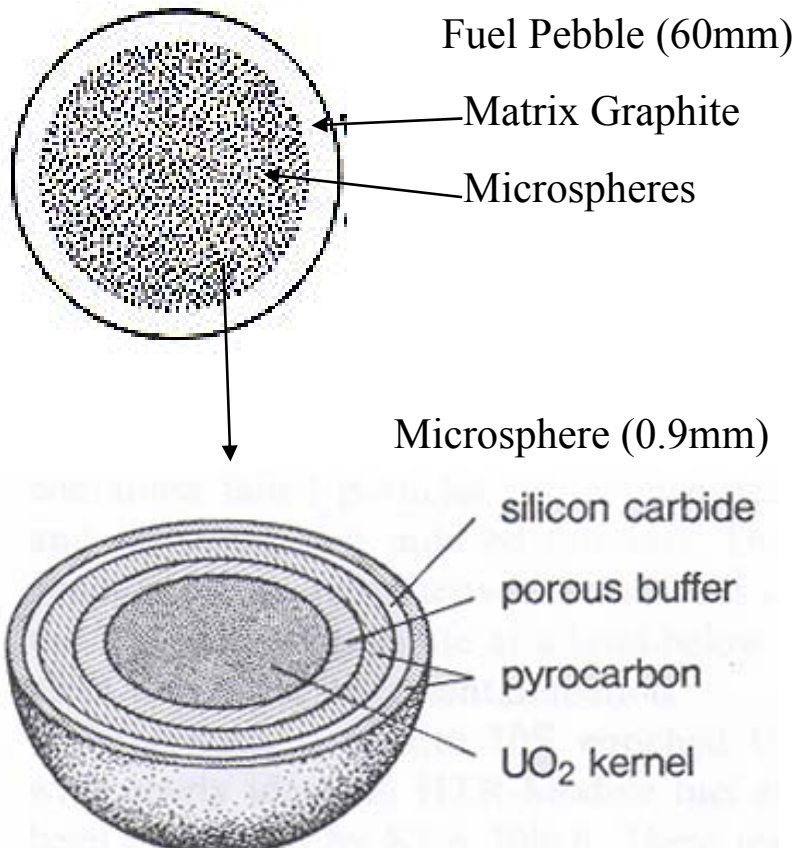

- 0.9mm diameter
- ~ 11,000 in every pebble
- $10^9$  microspheres in core
- Fission products retained inside microsphere
- TRISO acts as a pressure vessel
- Reliability
  - Defective coatings during manufacture
  - ~ 1 defect in every fuel pebble

# Fuel Components with Plutonium Load

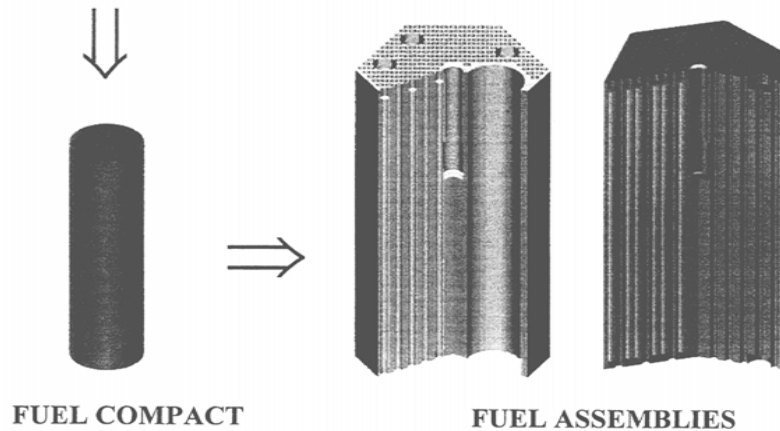
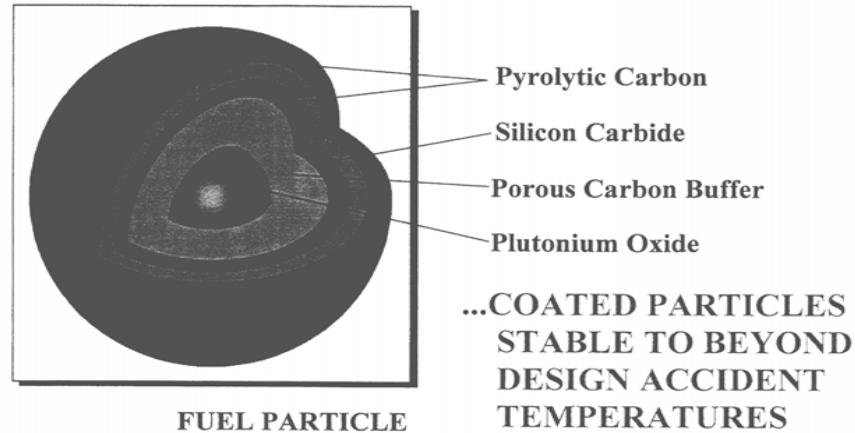

- Fuel Normal Peak Temperature 1200 °C
- Fuel Maximum Design Basis Event Temperature 1600 °C

# Comparison of 450 MWt and 600 MWt Cores

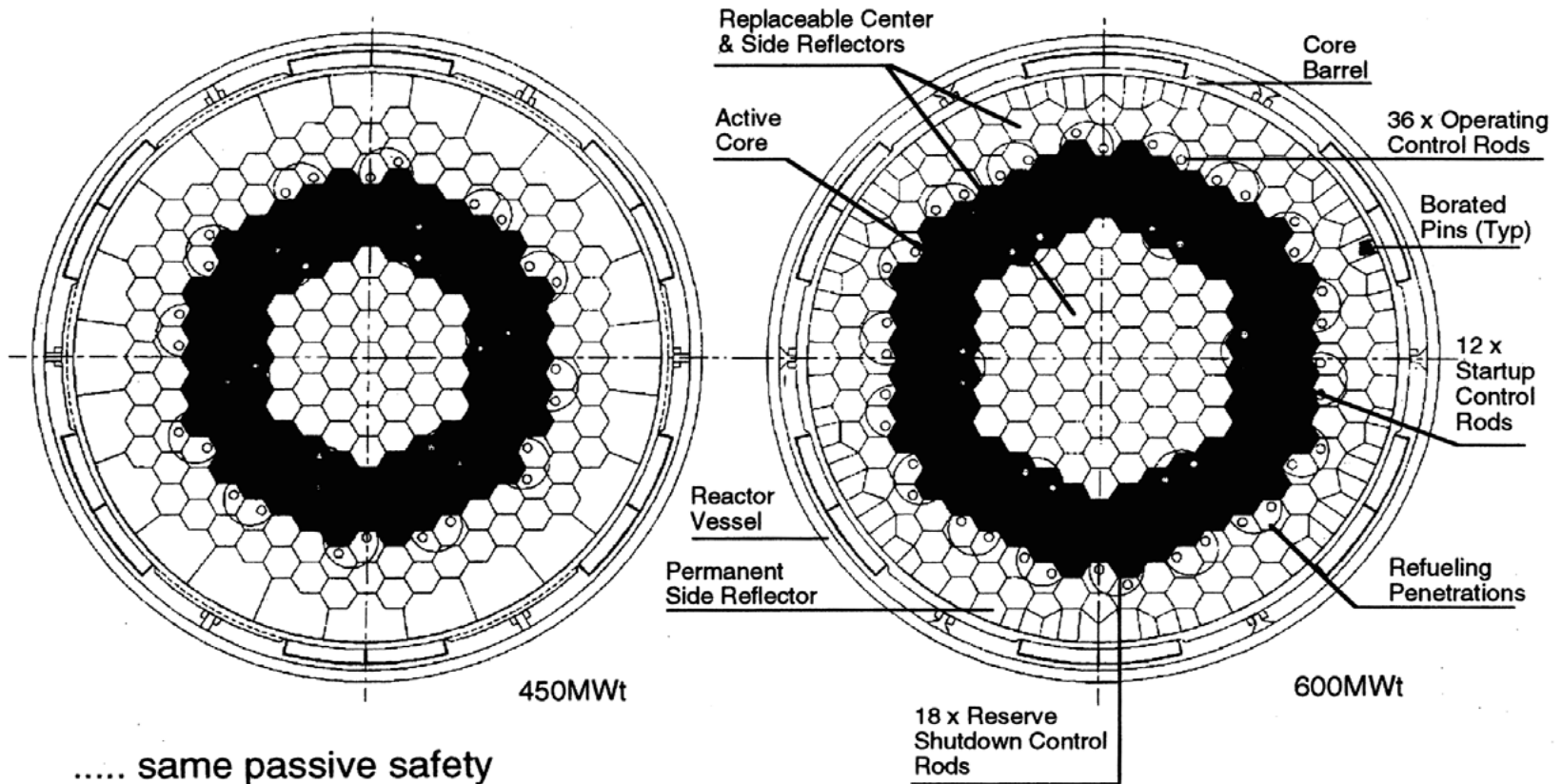

..... same passive safety

..... annular core using existing technology

# GT-MHR Flow Schematic

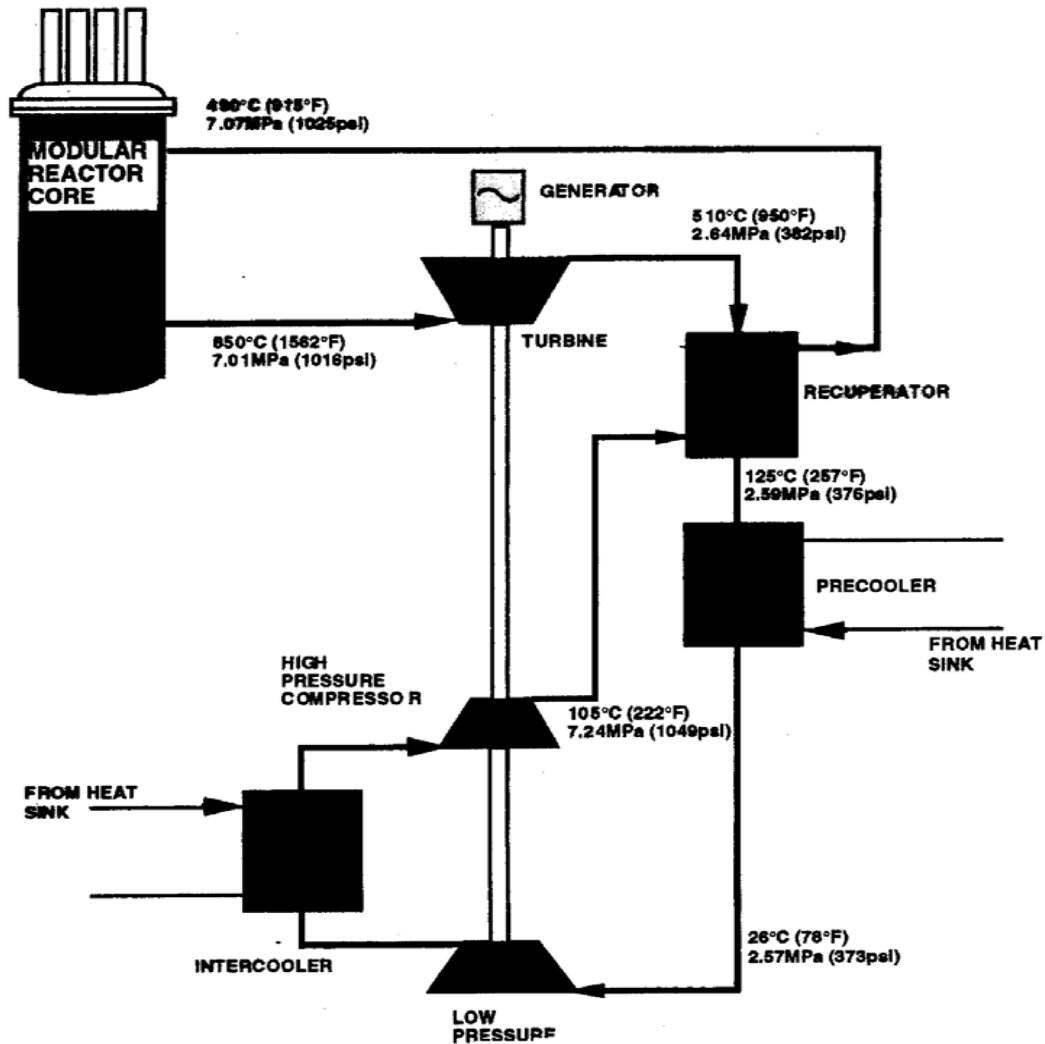

# Flow through Power Conversion Vessel

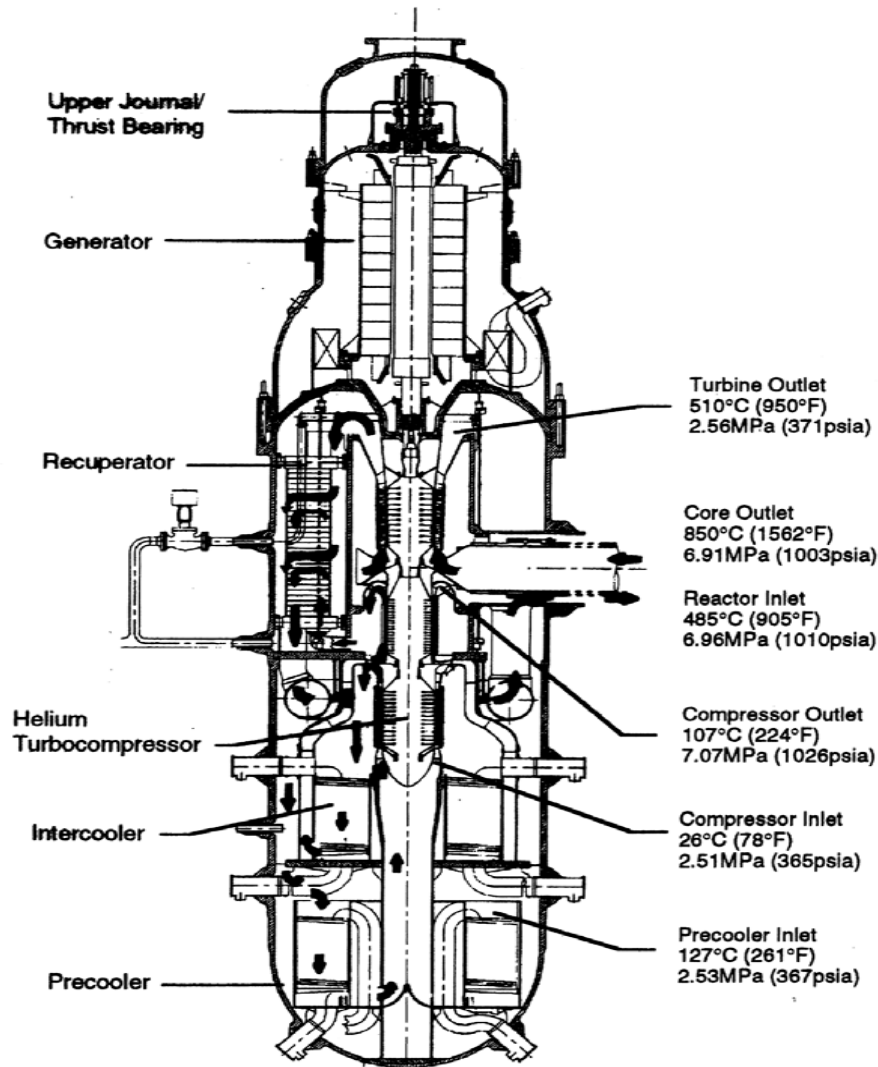

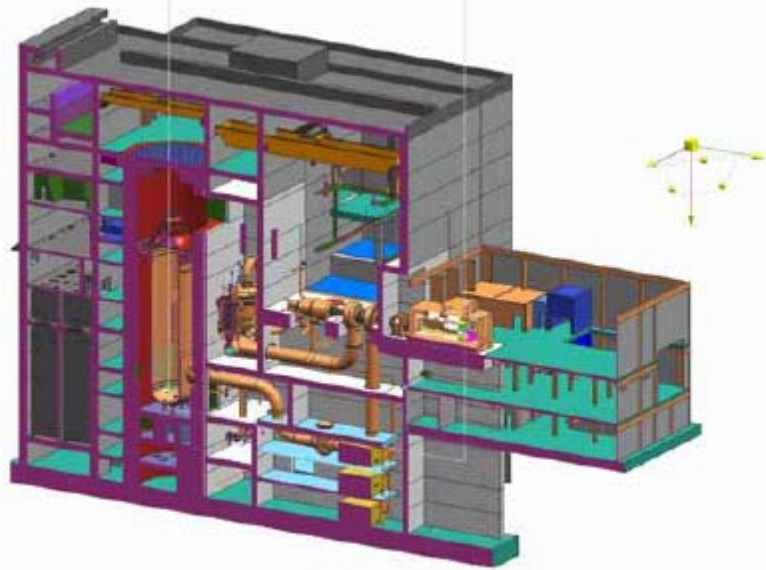

## Modular Pebble Bed Reactor South Africa - ESKOM

FIGURE 9. The 400 MWt single shaft main power system in the building.

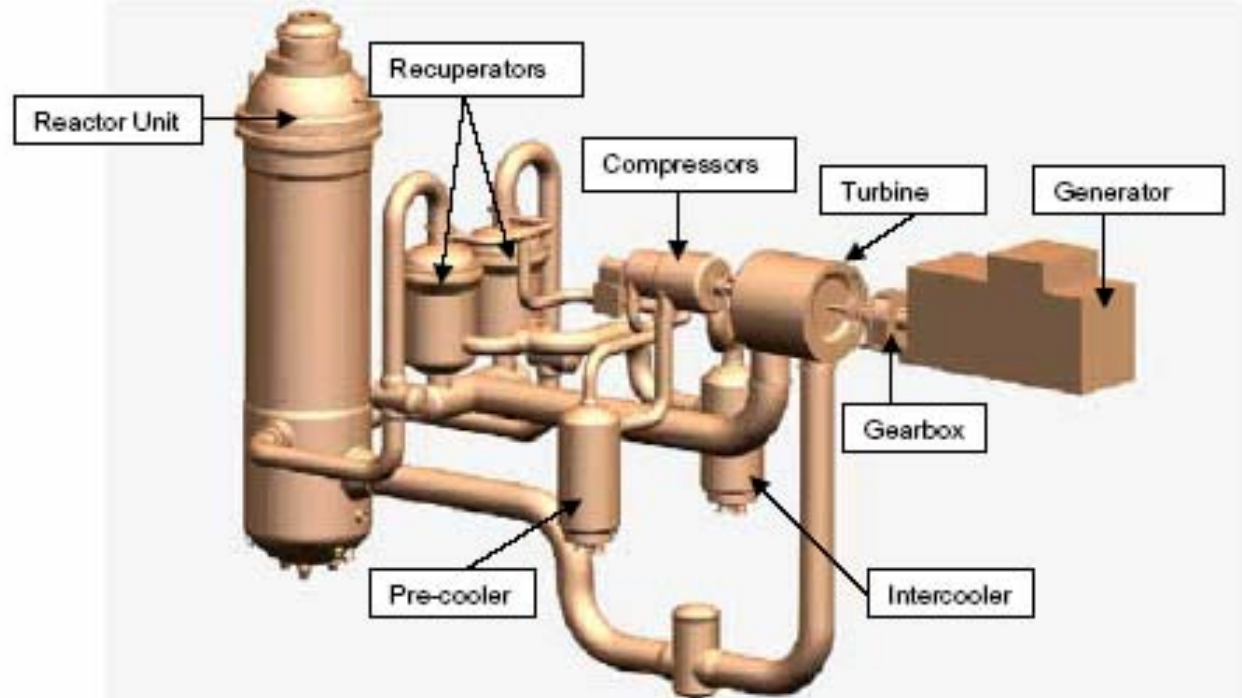

# FUEL ELEMENT DESIGN FOR PBMR

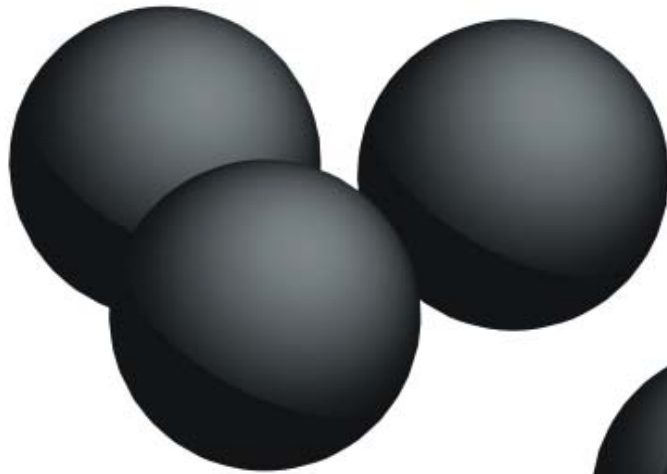

Dia. 60mm

**Fuel Sphere**

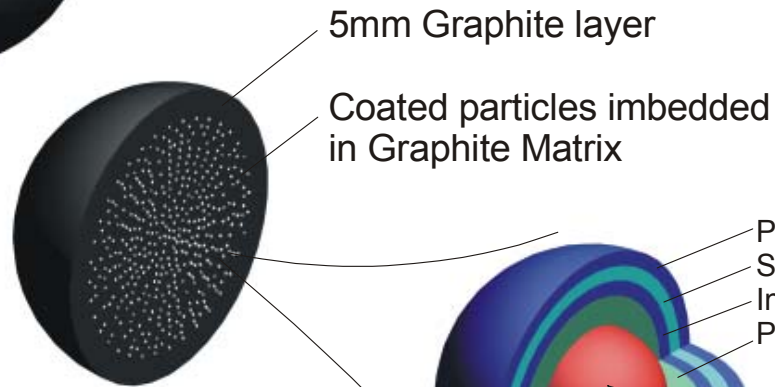

5mm Graphite layer

Coated particles imbedded  
in Graphite Matrix

**Half Section**

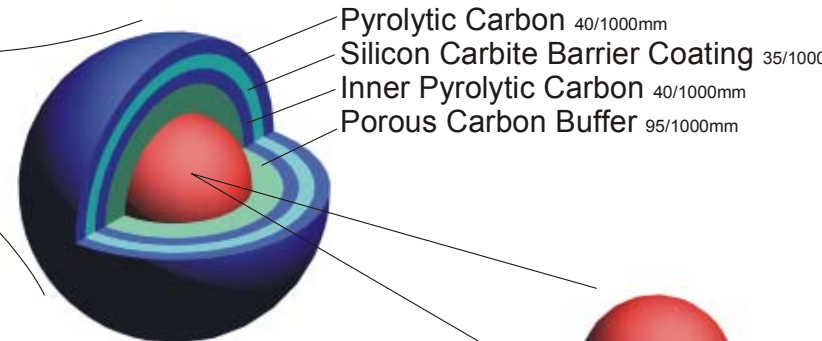

Pyrolytic Carbon 40/1000mm

Silicon Carbide Barrier Coating 35/1000mm

Inner Pyrolytic Carbon 40/1000mm

Porous Carbon Buffer 95/1000mm

Dia. 0,92mm

**Coated Particle**



Dia. 0,5mm

Uranium Dioxide

**Fuel**

# Differences Between LWRS

- Higher Thermal Efficiencies Possible
- Helium inert gas
- Minimizes use of water in cycle - corrosion
- Single Phase coolant – fewer problems in accident
- Utilizes gas turbine technology
- Lower Power Density – no meltdown potential
- Less Complicated Design (No ECCS)

# Advantages & Disadvantages

## Advantages

- Higher Efficiency
- Lower operating waste
- Higher Safety Margins
- High Burnup
  - 100 MWD/kg

## Disadvantages

- Poor History in US
- Little Helium Turbine Experience
- US Technology Water Based
- Licensing Hurdles due to different designs

# What is a Pebble Bed Reactor ?

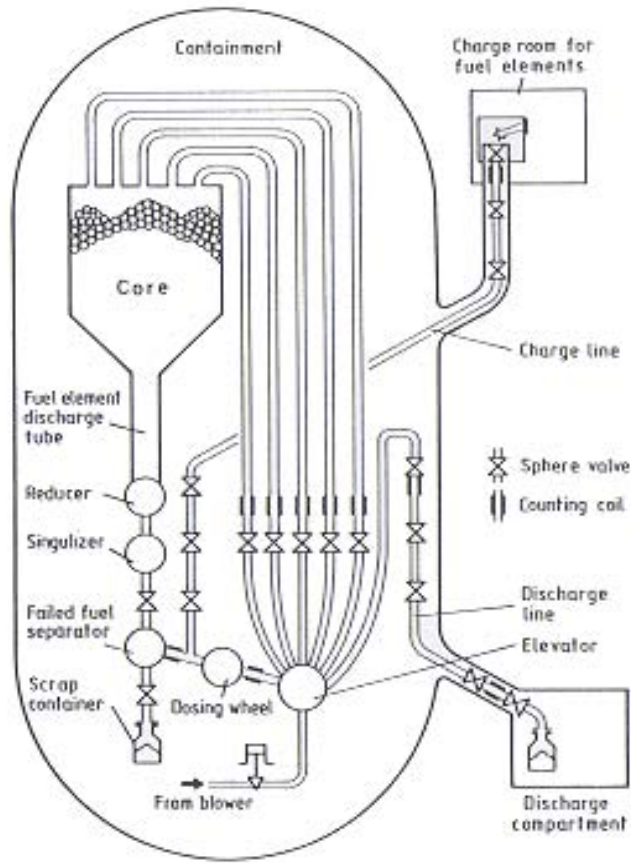

- 360,000 pebbles in core
- about 3,000 pebbles handled by FHS each day
- about 350 discarded daily
- one pebble discharged every 30 seconds
- average pebble cycles through core 10 times
- Fuel handling most maintenance-intensive part of plant

## Germany



AVR (1967-88)  
15 MWe

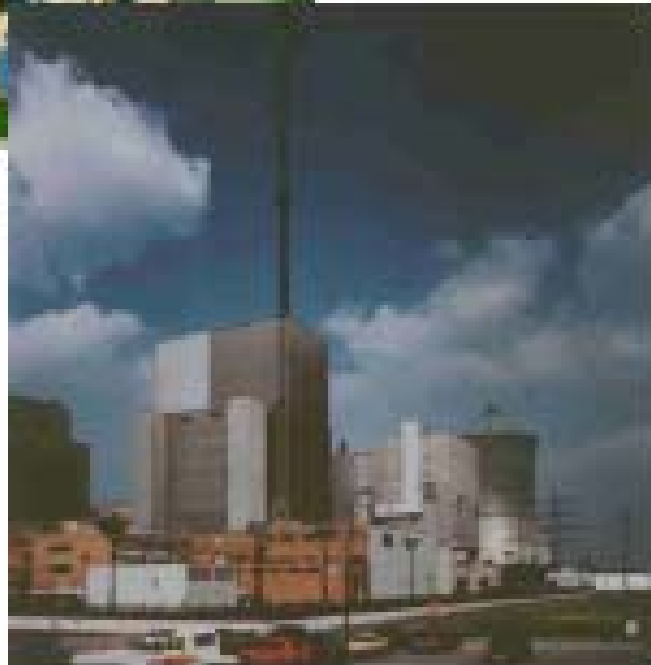

THTR (1985-89)  
300 MWe

# HTR- 10 China

## First Criticality Dec.1, 2000



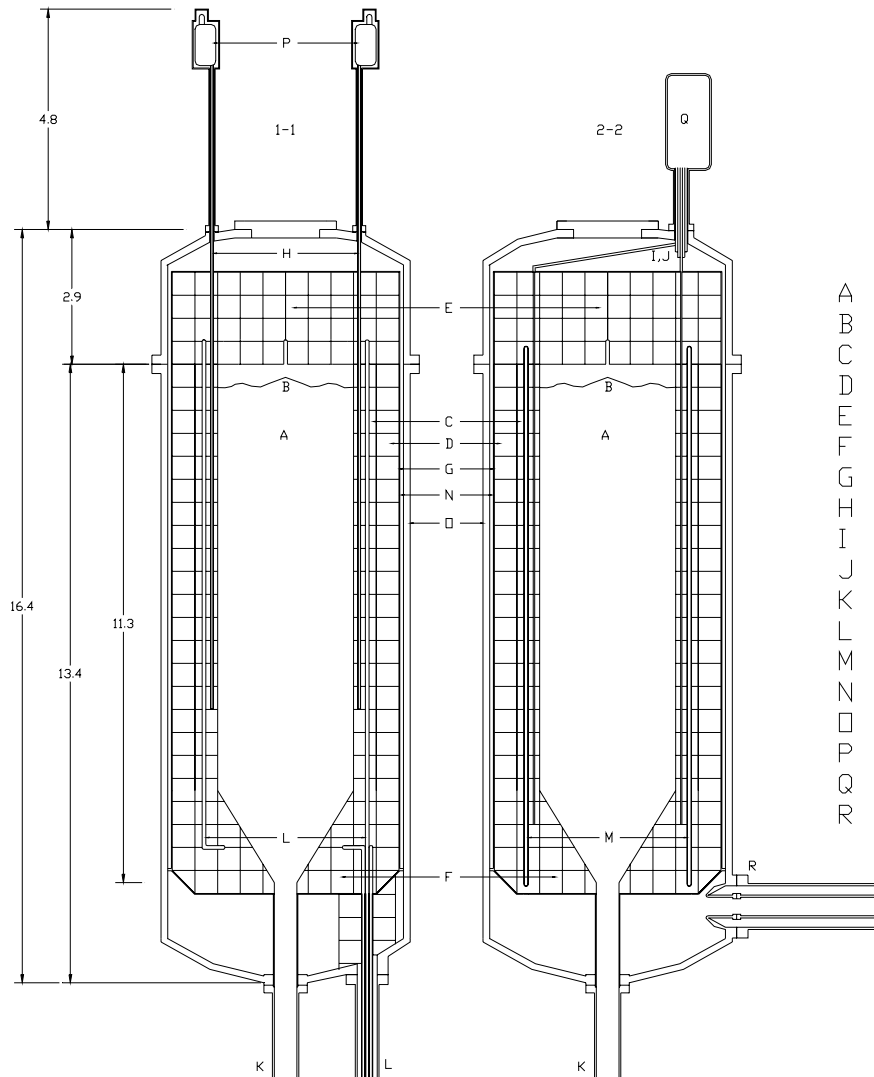

- A Pebble Bed Core
- B Fuel Drop Points (5)
- C Inner Reflector
- D Outer Reflector
- E Top Reflector
- F Bottom Reflector
- G Core Barrel
- H Control Rod Channels (6)
- I Absorber Ball Drop Channels (18)
- J Absorber Ball Lift Channel (1)
- K Fuel Discharge Tube
- L Pebble Fuel Lift Channels (5)
- M Coolant Flow Channels (6)
- N Stagnant Helium Gap
- Pressure Vessel
- P Control Rod Drivers
- Q Absorber Ball Container
- R Coaxial Pipe to IHX Module

# Reactor Unit

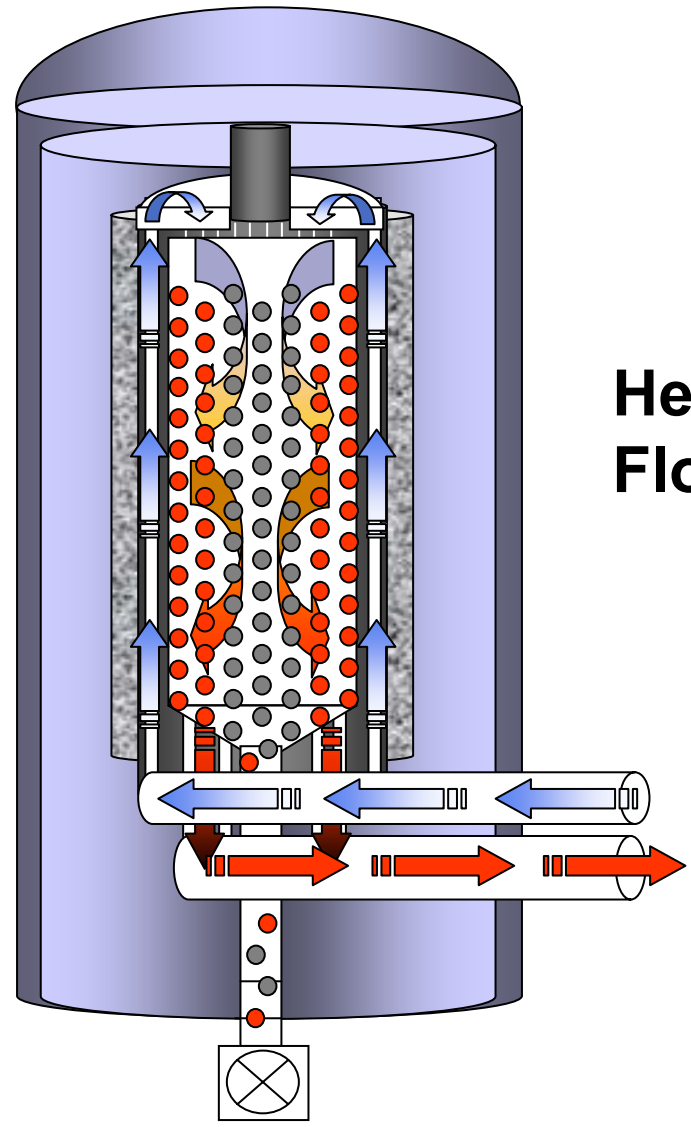

**Helium  
Flowpath**

# Fuel Handling & Storage System

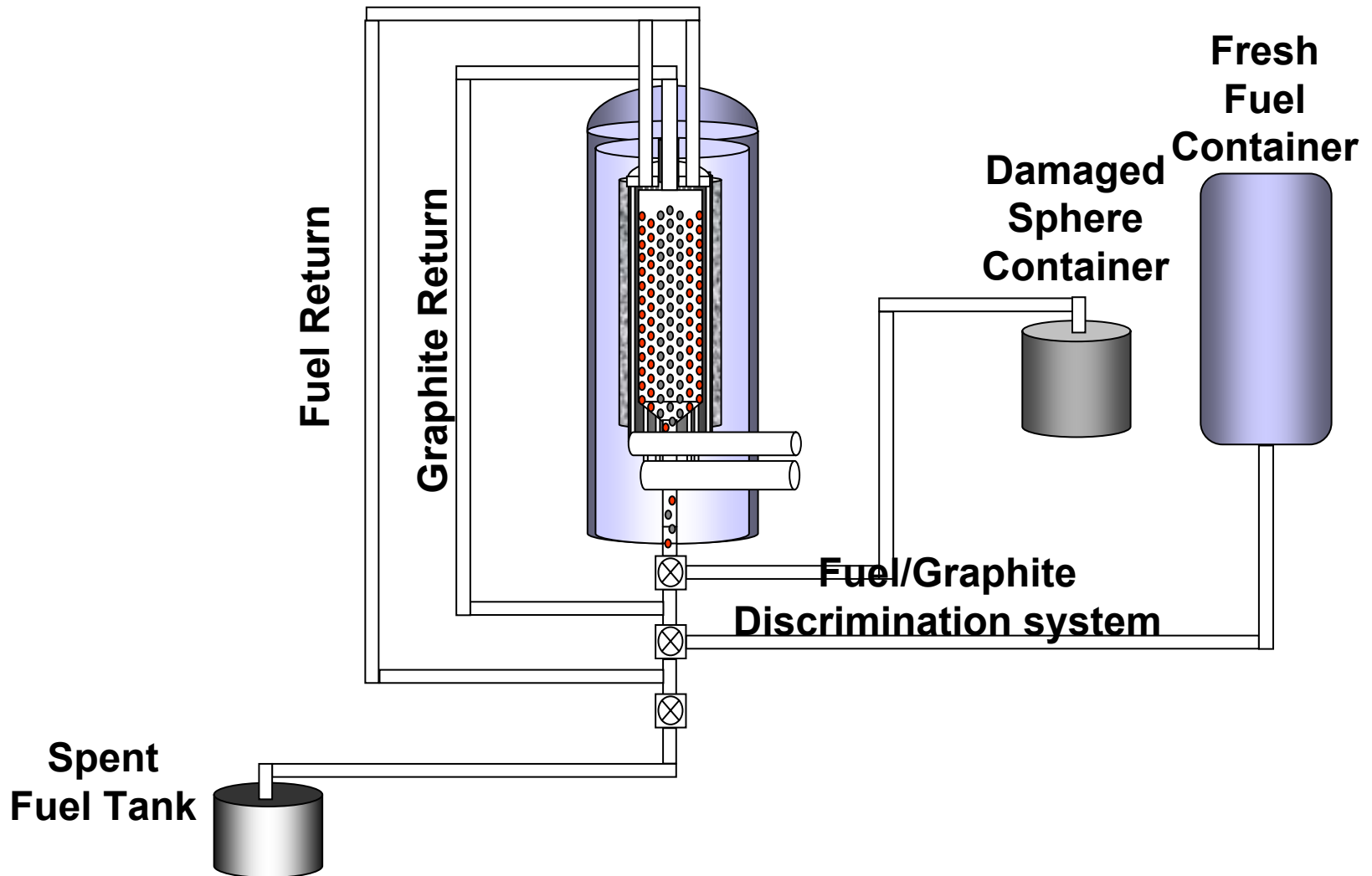

# Pebble Bed Reactor Designs

- PBMR (ESKOM) South African
  - Direct Cycle
- China – Indirect He/Steam Cycle
- MIT Design
  - Indirect Cycle - Intermediate He/He HX
  - Modular Components - site assembly

# MIT Project Overview

- **Fuel Performance**
- **Fission Product Barrier**  
(silver migration)
- **Core Physics**
- **Safety**
  - **Loss of Coolant**
  - **Air Ingress**
- **Balance of Plant Design**
- **Modularity Design**
- **Intermediate Heat Exchanger Design**
- **Core Power Distribution Monitoring**
- **Pebble Flow Experiments**
- **Non-Proliferation**
- **Safeguards**
- **Waste Disposal**
- **Reactor Research/  
Demonstration Facility**
- **License by Test**
- **Expert I&C System -  
Hands free operation**

# Safety Issues

- Fuel Performance - Key to safety case
- Air Ingress
- Water Ingress
- Loss of Coolant Accident
- Seismic reactivity insertion
- Reactor Cavity Heat Removal
- Redundant Shutdown System
- Silver and Cesium diffusion

# Safety Advantages

- Low Power Density
- Naturally Safe
- **No melt down**
- No significant radiation release in accident
- Demonstrate with actual test of reactor



# “Naturally” Safe Fuel

Fuel Failure

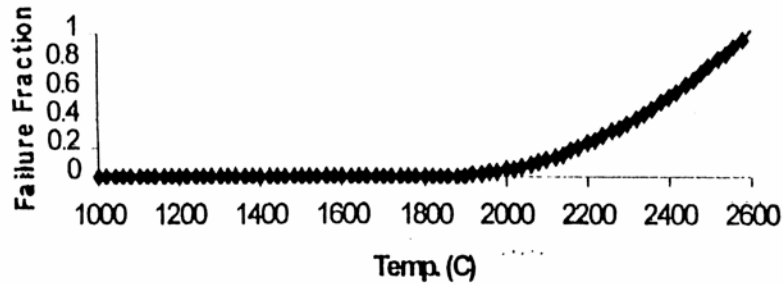

Time to Max Fuel Temp.

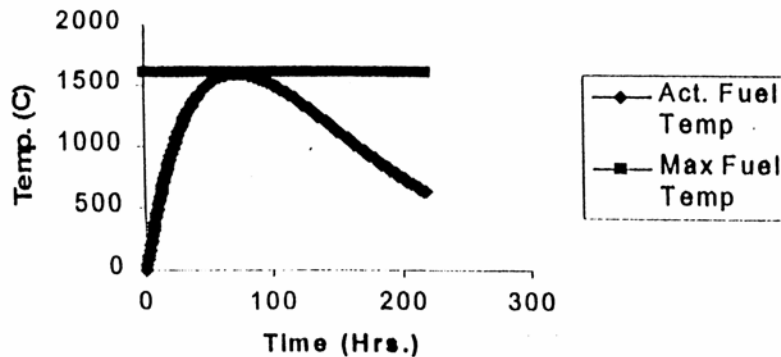

- Shut Off All Cooling
- Withdraw All Control Rods
- No Emergency Cooling
- No Operator Action

# Temperature Profile

Fig-10: The Temperature Profile in the 73rd Day

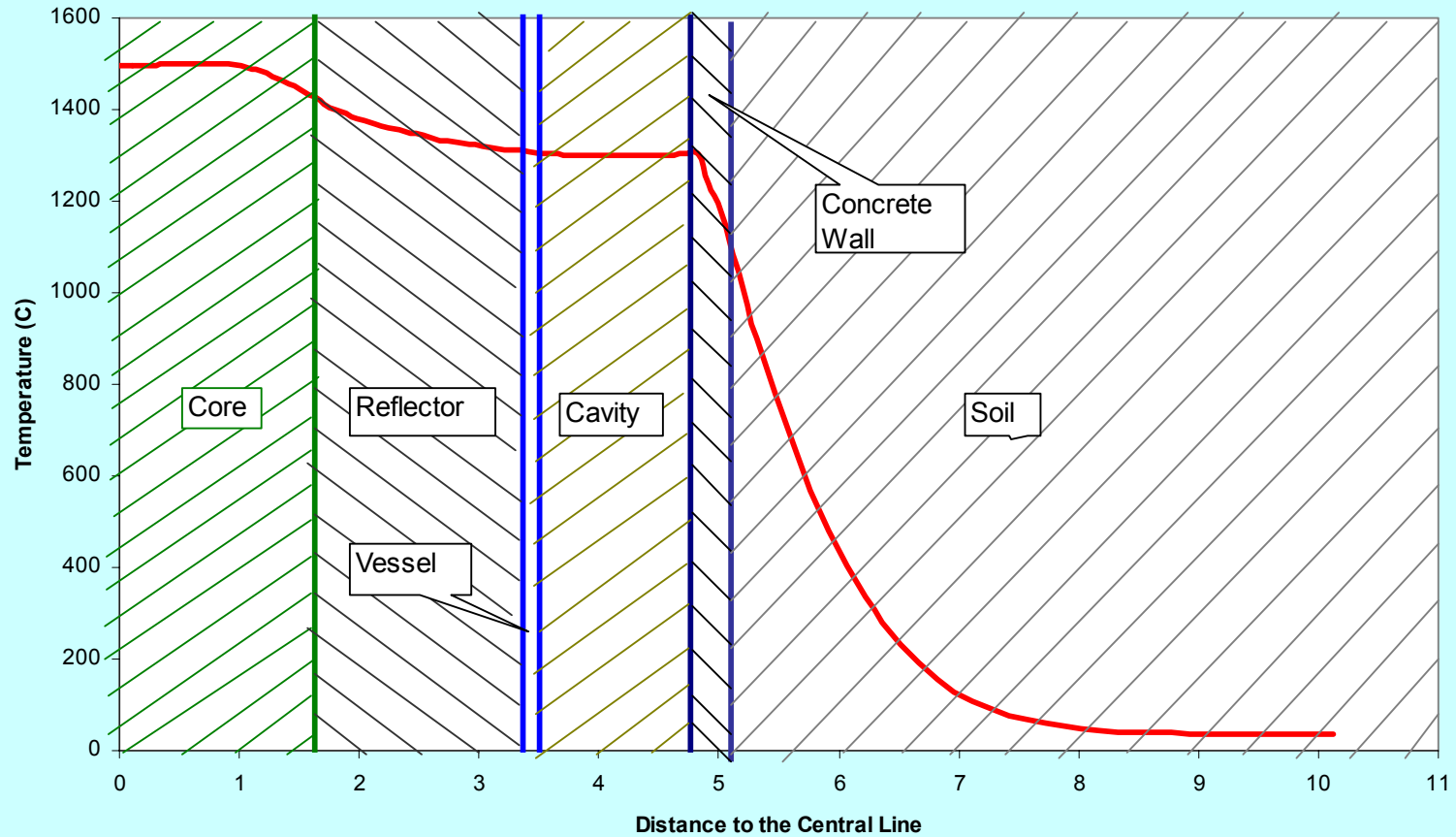

# Simplified HEATING7 Open Cylinder Analysis Peak Temperature

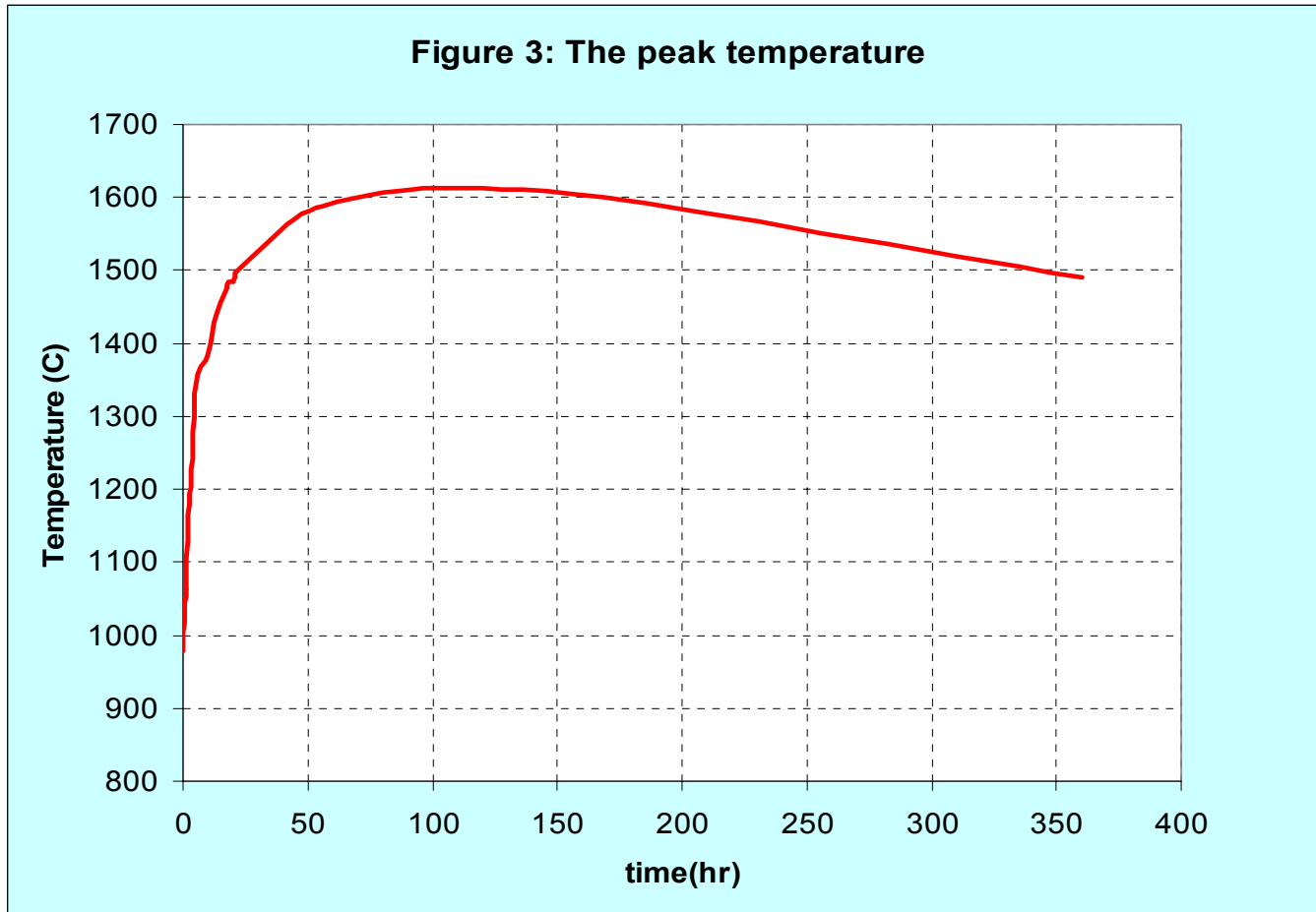

# The Prediction of the Air Velocity

## (By Dr. H. C. No)

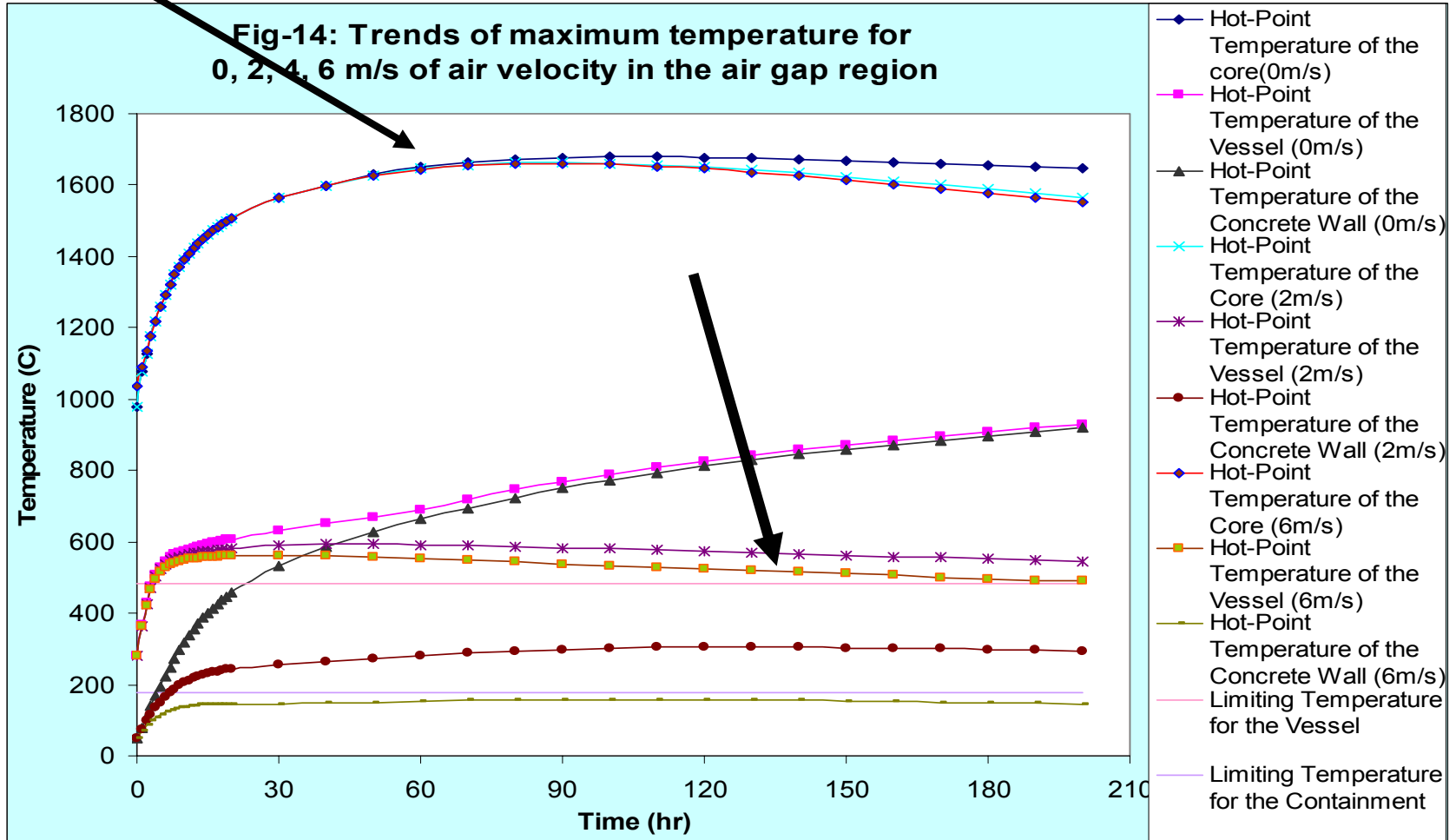

# Fuel Performance Model

- Detailed modeling of fuel kernel
- Microsphere
- Monte Carlo Sampling of Properties
- Use of Real Reactor Power Histories
- Fracture Mechanics Based
- Considers Creep, stress, strains, fission product gases, irradiation and temperature dependent properties.

# TIM Code Model

## Fuel Performance Code

- Deals Explicitly With Statistical Nature of Fuel Characteristics, Materials Properties Uncertainty, and Power History Uncertainty (Fueling Scheme in PBMR) Using Monte Carlo Techniques.
- Advanced Fracture Mechanics Model for PyC and SiC Failure.
- Able to Model Prismatic as well as Pebble Bed Cores
- Results Compare Well With Irradiation Experiments
- Chemical Model-In Progress

# Fuel Optimization Criteria

## Considered Fuel Failure Mechanisms

- Over-pressurization failure by tensile stress
- Crack-in-pyrocarbon induced failure by stress concentration



## Fuel Optimization Criteria

- Minimize the maximum stresses in IPyC and OPyC layers
- Maximize the gap between Weibull strength and maximum stress for IPyC and OPyC layers
- Keep the maximum stress in SiC layer non-positive

# Barrier Integrity

- Silver leakage observed in tests @ temps
- Experiments Proceeding with Clear Objective - Understand phenomenon
- Palladium Attack Experiments Underway
- Zirconium Carbide being tested as a reference against SiC.
- Focus on Grain SiC Structure Effect
- Will update model with this information

# Ion Implantation Silver Depth Profile

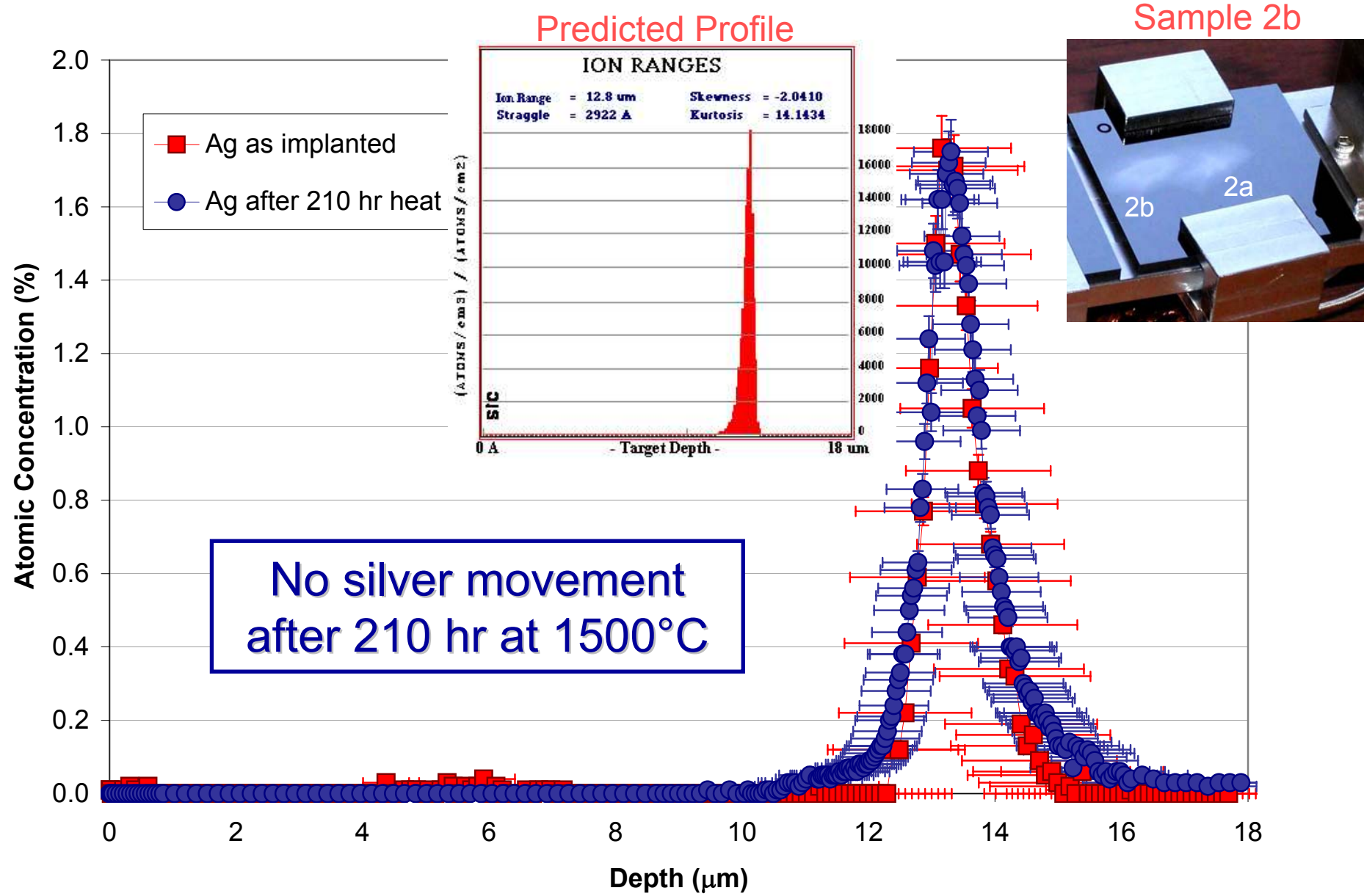

# Core Physics

- Basic tool Very Special Old Programs (VSOP)
- Developed MNCP Modeling Process
- Tested Against HTR-10 Benchmark
- Tested Against ASTRA Tests with South African Fuel and Annular Core
- VSOP Verification and Validation Effort



# MCNP4B Modeling of Pebble Bed Reactors

## *Steps in Method Development*

PROTEUS critical experiments @ PSI	<ul style="list-style-type: none"><li>▪ simple cores</li><li>▪ stochastic packing</li></ul>
HTR-10 physics benchmark	<ul style="list-style-type: none"><li>▪ predict criticality</li><li>▪ <i>cf.</i> measurement</li></ul>
ASTRA critical experiments @ KI	<ul style="list-style-type: none"><li>▪ mockup of PBMR</li><li>▪ annular core</li></ul>
PBMR South Africa	<ul style="list-style-type: none"><li>▪ startup core</li><li>▪ MCNP <i>vs.</i> VSOP</li></ul>



# HTR-10 (*Beijing*)

## 10 MW Pebble Bed Reactor:

- Graphite reflector
- Core:  $R_c = 90$  cm,  $H \leq 197$  cm
- TRISO fuel with 5 g U/Fuel Sphere
- 17% U235
- F/M *sphere* ratio = 57:43, modeled by reducing moderator sphere size
- Initial criticality December 2000

### MCNP4B Results

K-eff	1.00081±0.00086
Critical Height	128.5 cm
Calculated Loading	16,830
Actual Loading	16,890

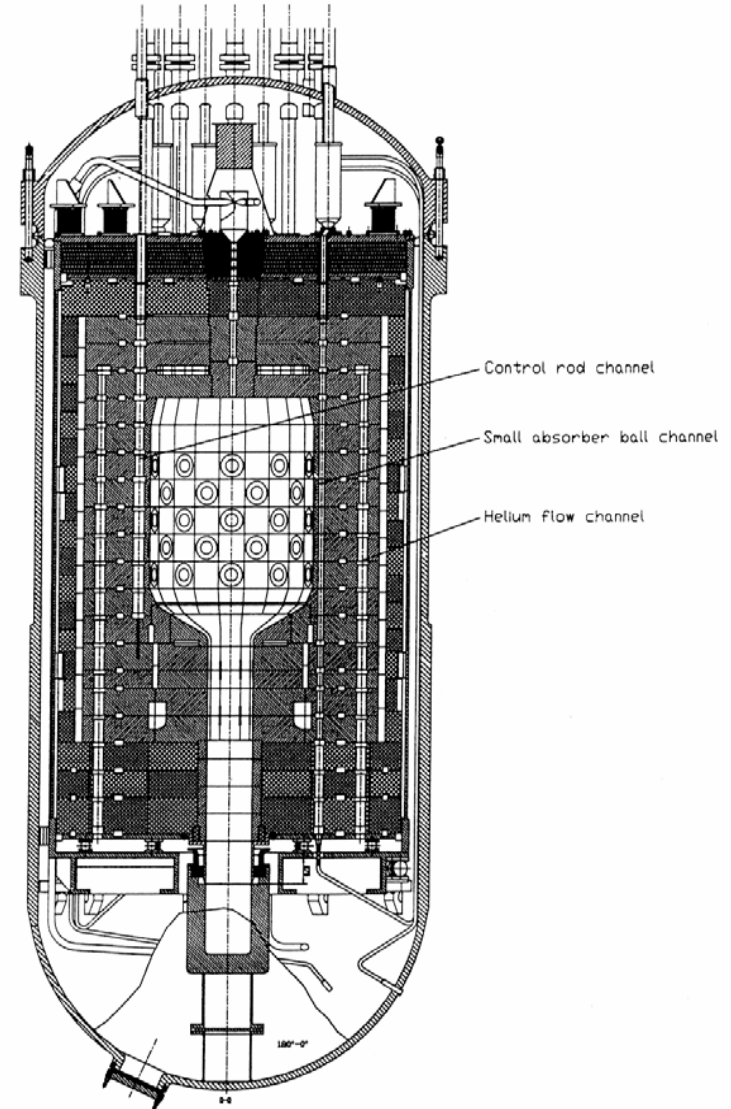

# Air Ingress

- **Most severe accidents among PBMR's conceivable accidents with a low occurrence frequency.**
- **Challenges: Complex geometry, Natural Convection, Diffusion, Chemical Reactions**

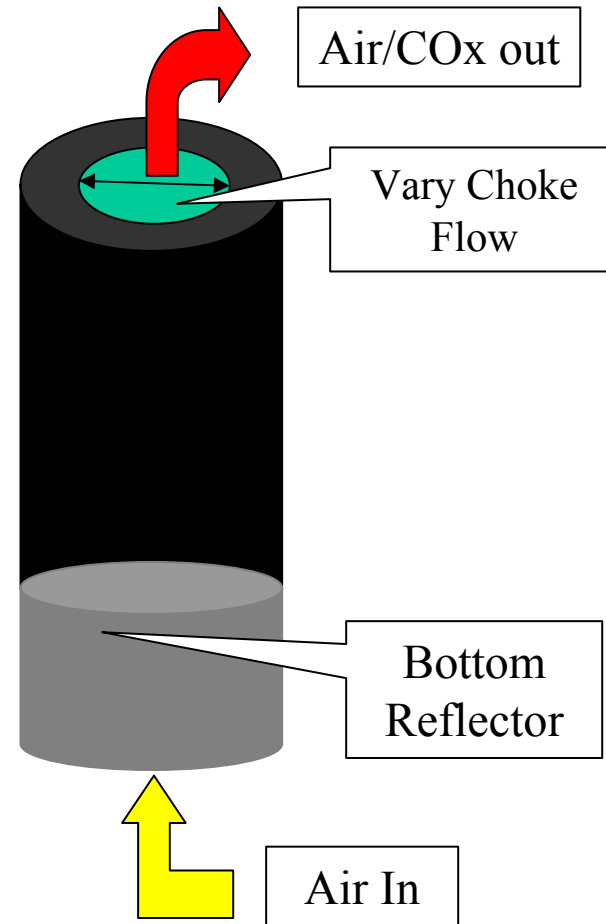

# The Characteristics the Accident

- **Important parameters governing these reactions**
  - Graphite temperature
  - Partial pressures of the oxygen
  - Velocity of the gases
- **Three Stages:**
  - Depressurization (10 to 200 hours)
  - Molecular diffusion.
  - Natural circulation

# Critical Parameters for Air Ingress

- Temperature of reacting components
- The concentration of oxygen
- Gas flow rates
- Pressure (partial pressure and total pressure in the system)

# Air Ingress Velocity f(temperature)

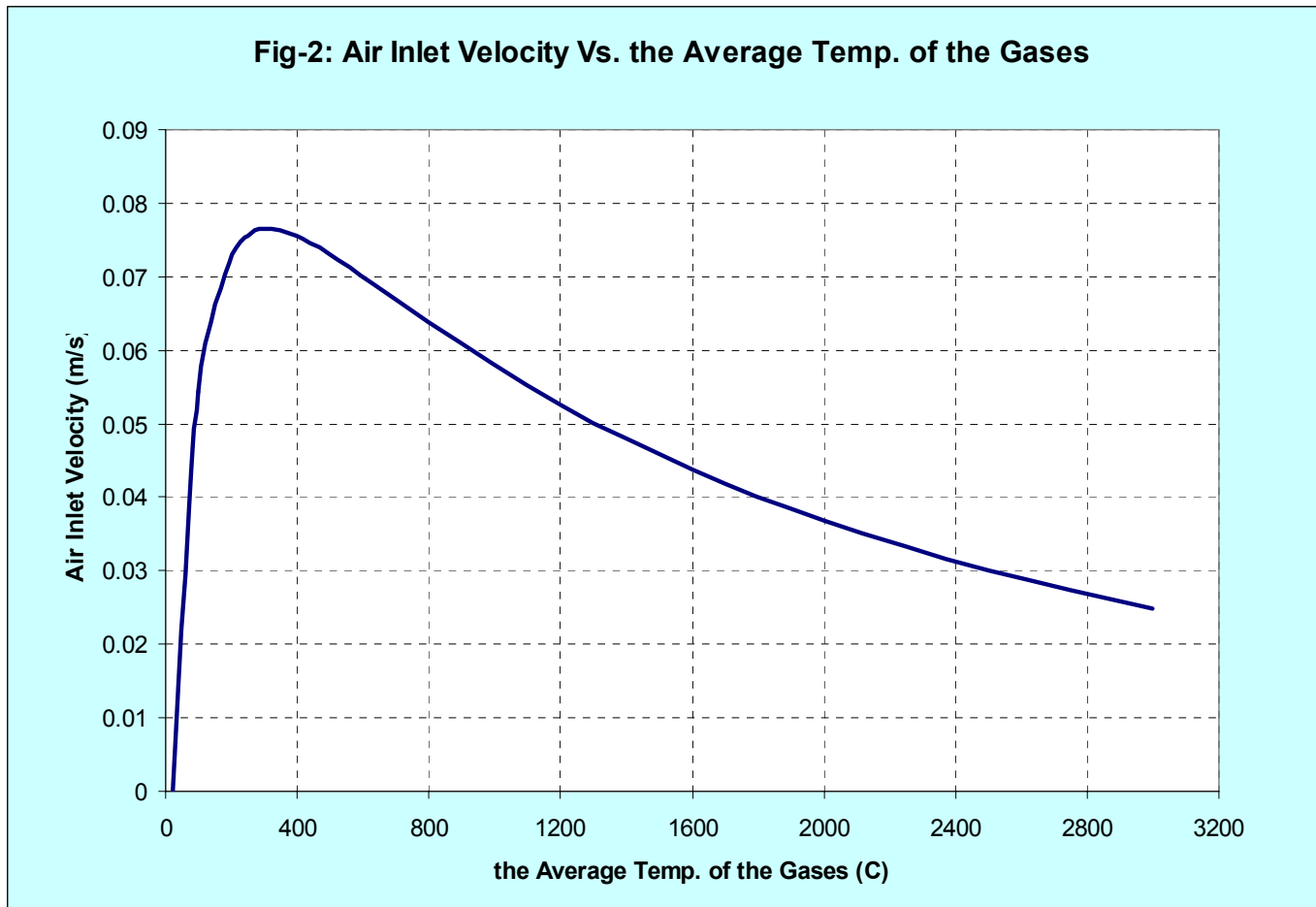

# Multi-Component experiment

## Japanese Air Ingress Tests

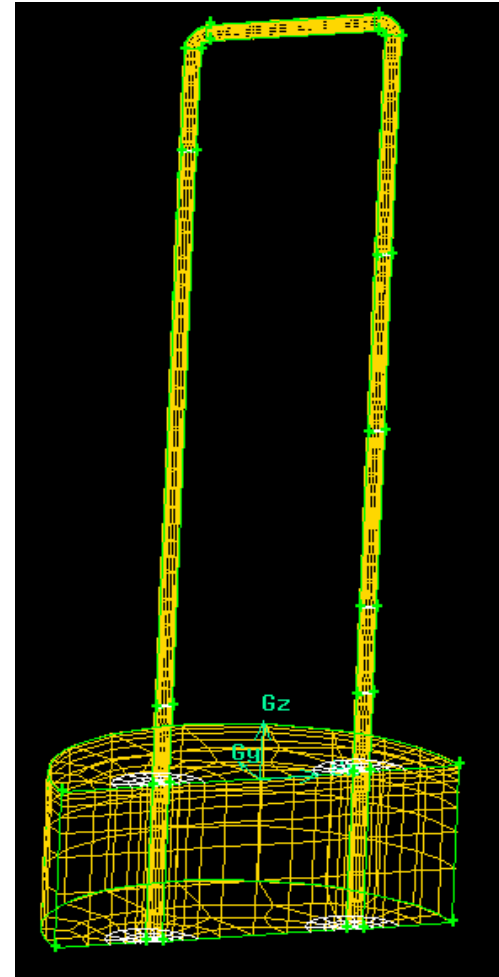
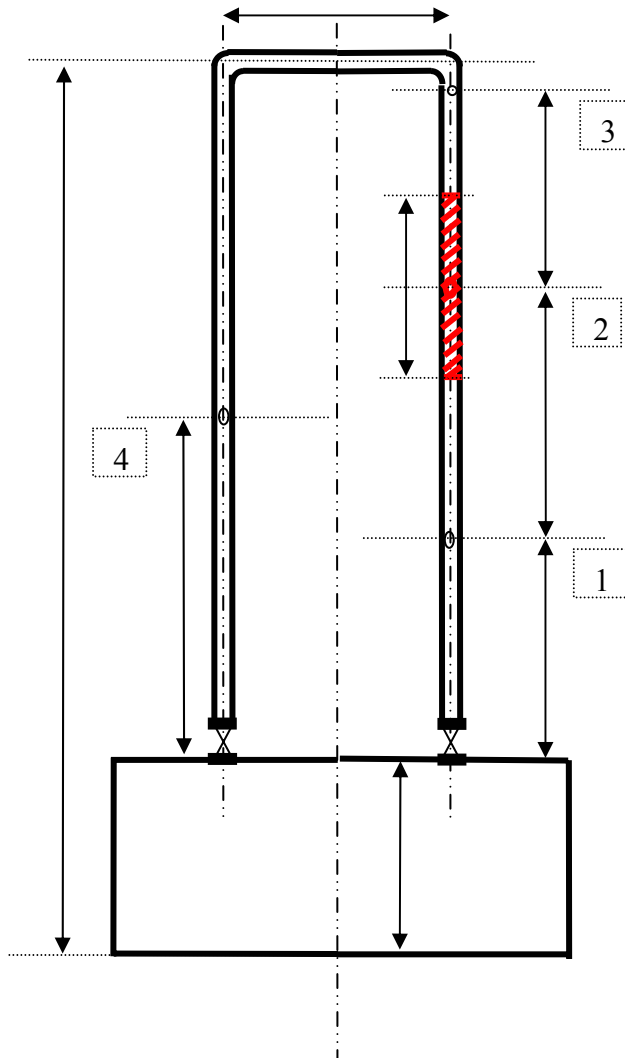

# Multi-Component Experiment

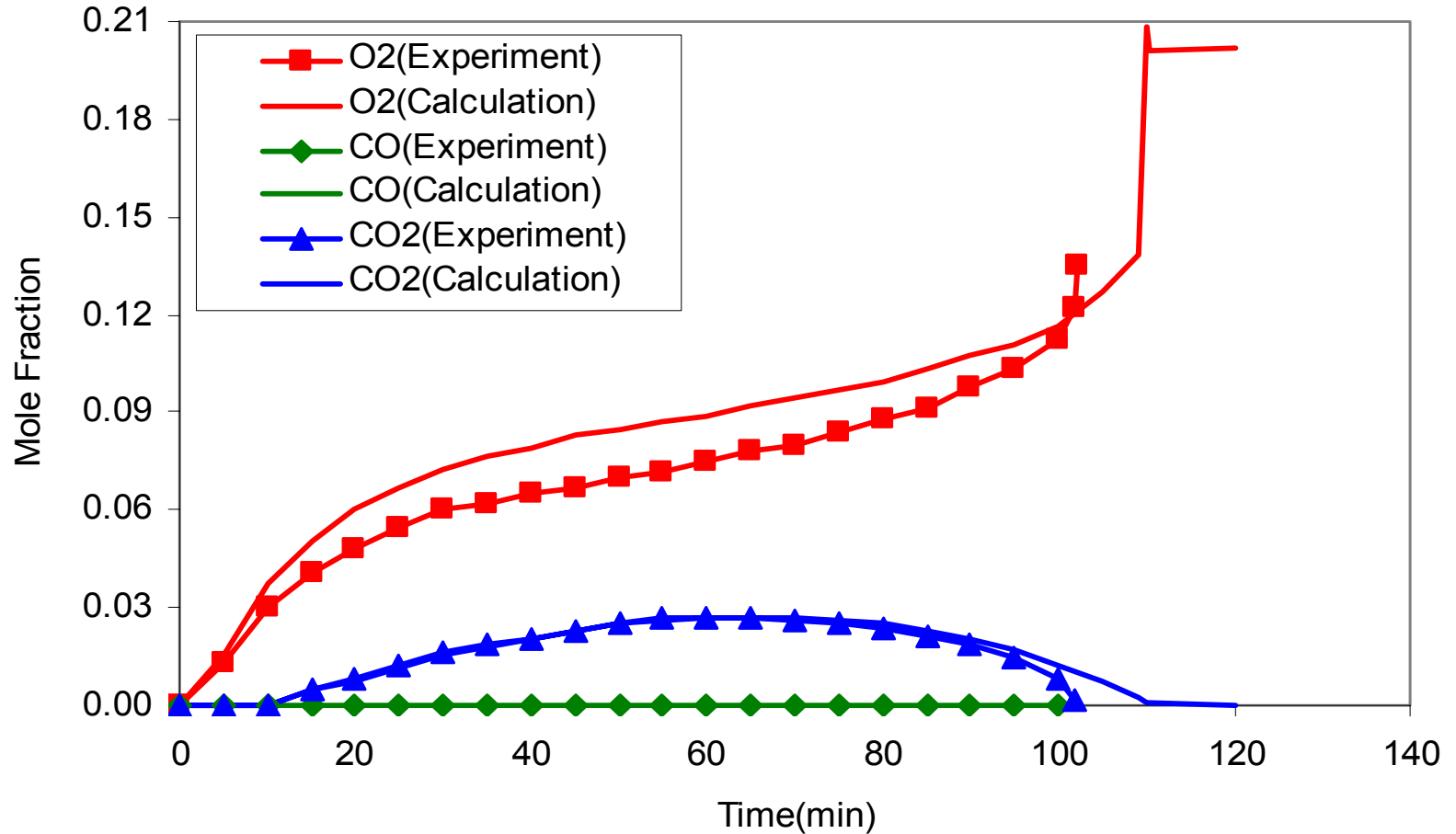

Figure 36: Mole Fraction at Point-1 (80% Diffusion Coeff.)

# Multi-Component Experiment(Cont.)

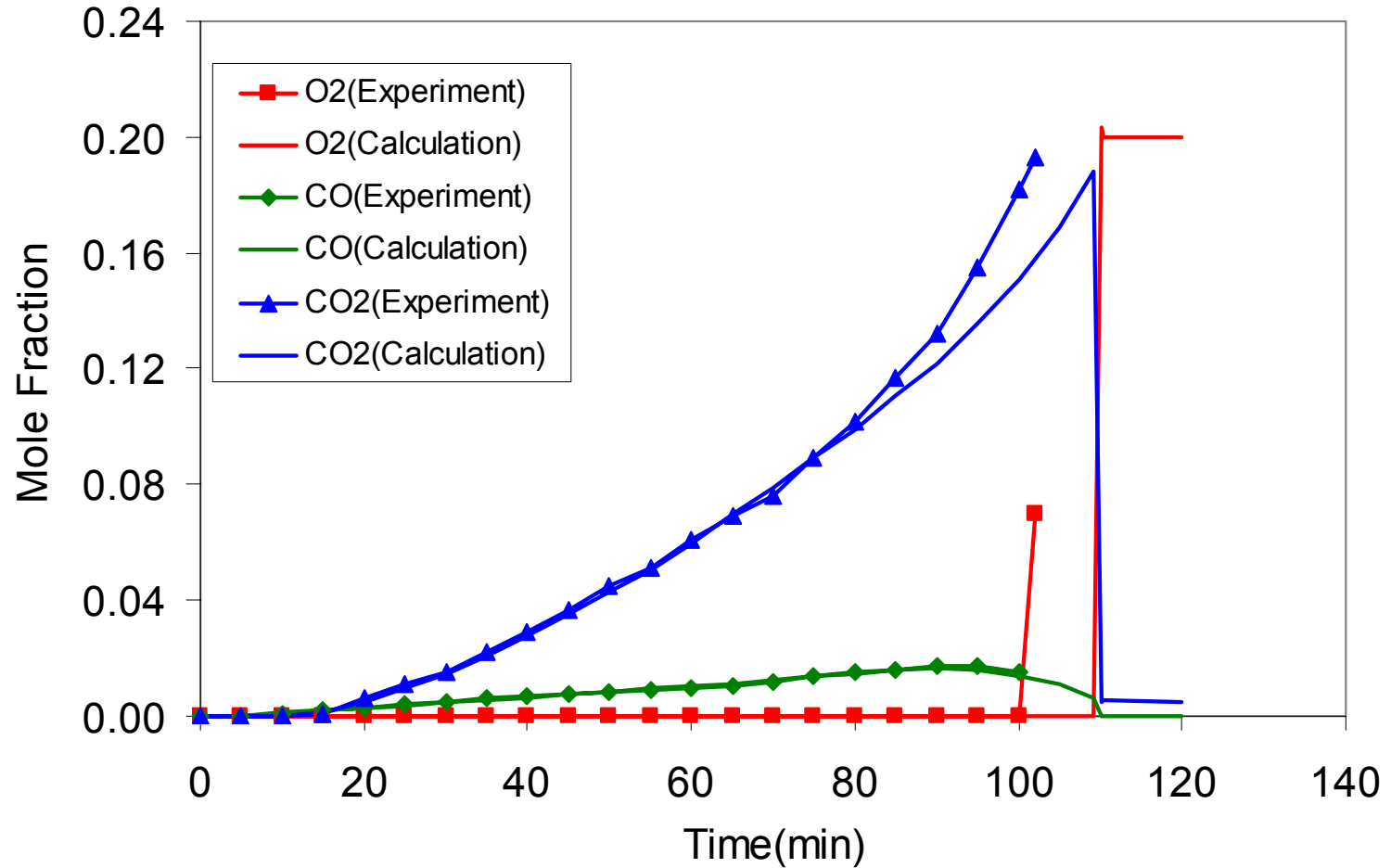

Figure 37: Mole Fraction at Point-3

# Multi-Component

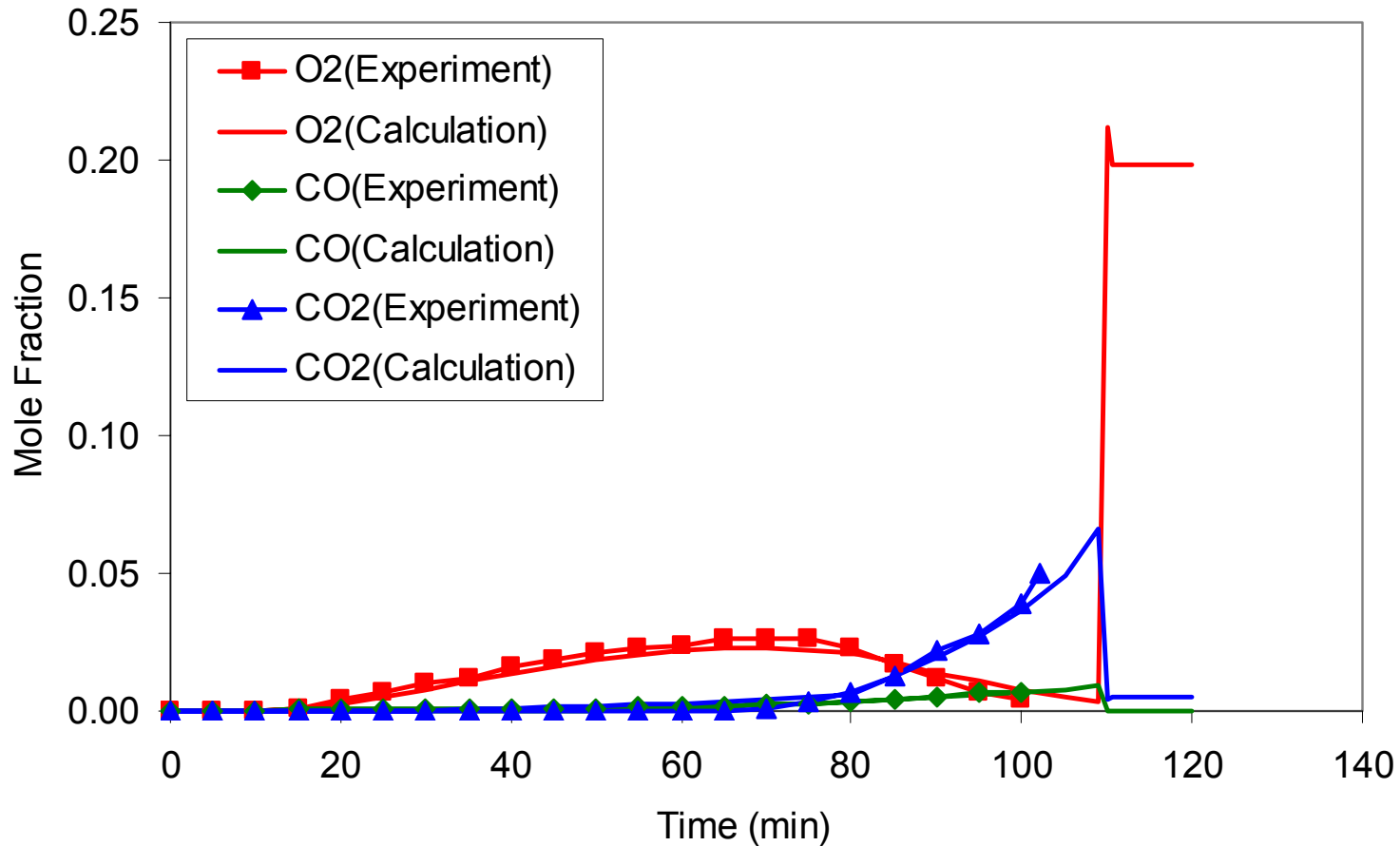

Figure 38: Mole Fraction at Point-4

# NACOK Natural Convection Experiments

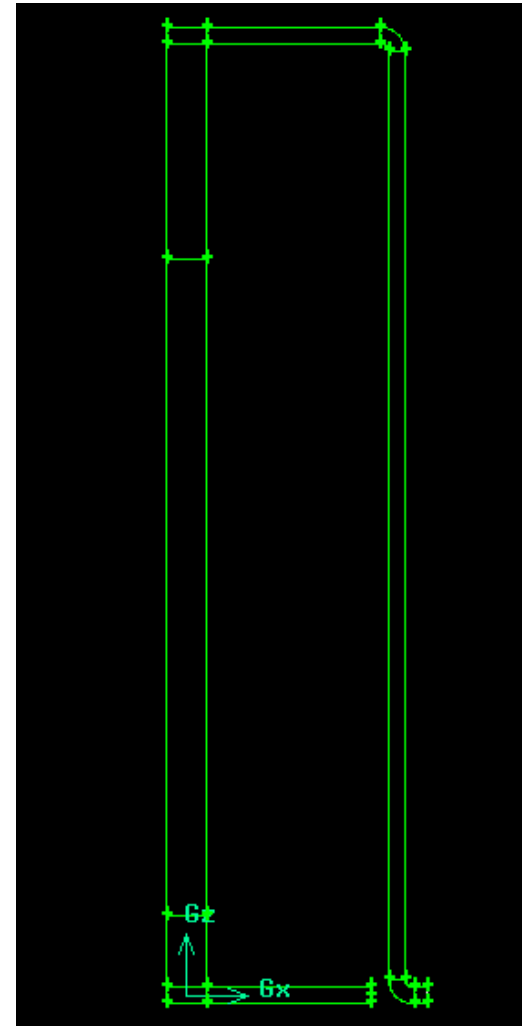
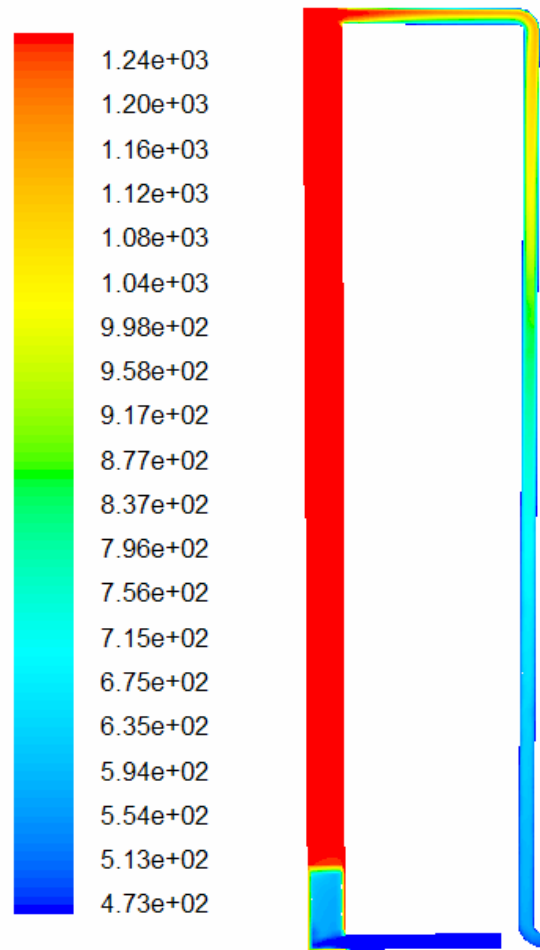

Figure 39: NACOK Experiment

# Boundary Conditions



**Figure 41: Temperature Profile for one experiment**

# The Mass Flow Rates

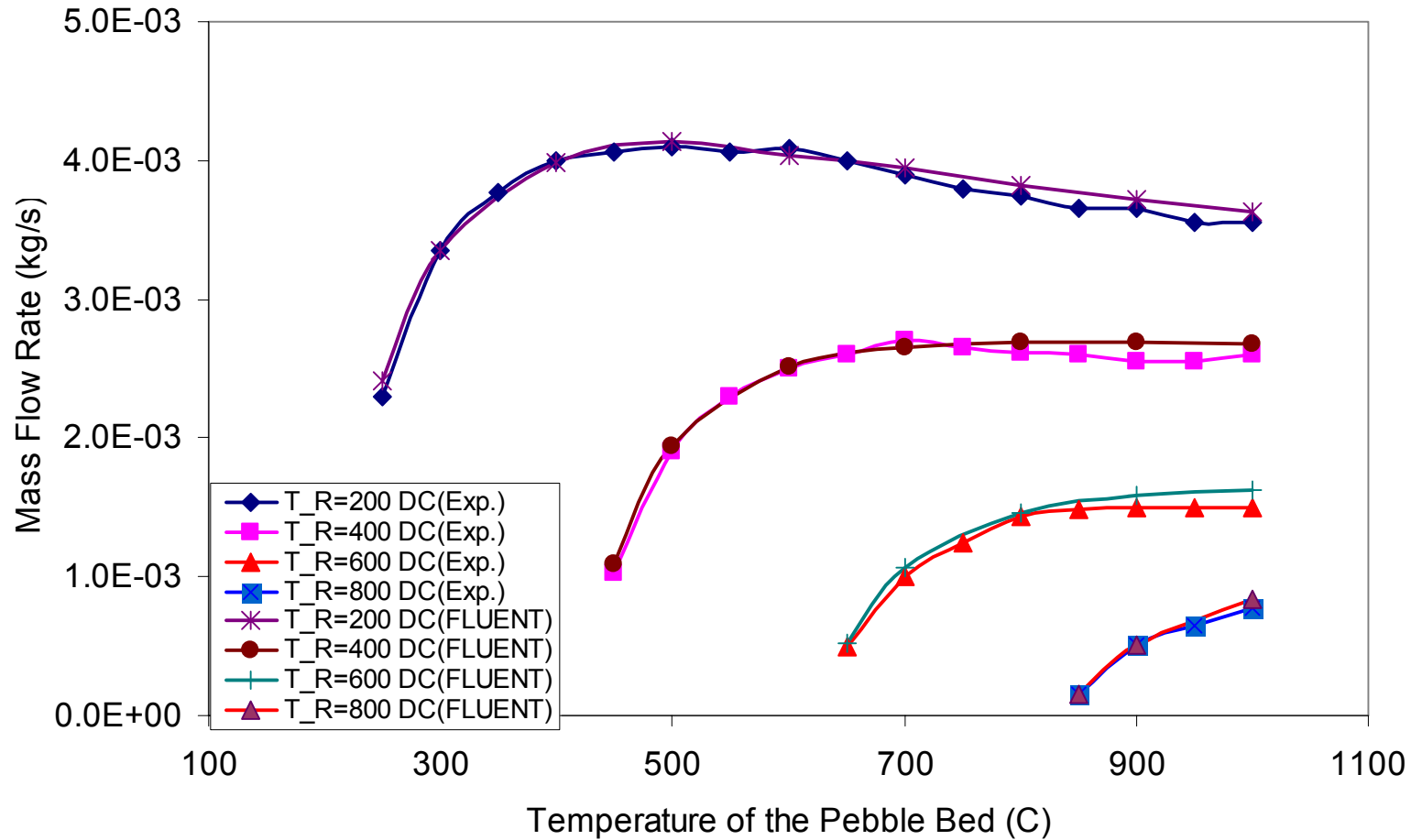

Figure 42: Mass Flow Rates for the NACOK Experiment

# Future NACOK Tests

- Blind Benchmark using MIT methodology to reproduce recent tests.
- Update models
- Expectation to have a validated model to be used with system codes such as RELAP and INL Melcor.

# Preliminary Conclusions

## Air Ingress

For an open cylinder of pebbles:

- Due to the very high resistance through the pebble bed, the inlet air velocity will not exceed 0.08 m/s.
- The negative feedback: the Air inlet velocity is not always increase when the core is heated up. It reaches its peak value at 300 °C.
- Preliminary combined chemical and chimney effect analysis completed - peak temperatures about 1670 C.

# Overall Safety Performance Demonstration and Validation

- China's HTR-10 provides an excellent test bed for validation of fundamentals of reactor performance and safety.
- Japan's HTTR provides a similar platform for block reactors.
- Germany's NACOK facility vital for understanding of air ingress events for both types.
- PBMR's Helium Test Facility, Heat Transfer Test Facility, Fuel Irradiation Tests, PCU Test Model.
- Needed - open sharing of important technical details to allow for validation and common understanding.

# Chinese HTR-10 Safety Demonstration

- Loss of flow test
  - Shut off circulator
  - Restrict Control Rods from Shutting down reactor
  - Isolate Steam Generator - no direct core heat removal only but vessel conduction to reactor cavity

# Video of Similar Test

# Loss of Cooling Test

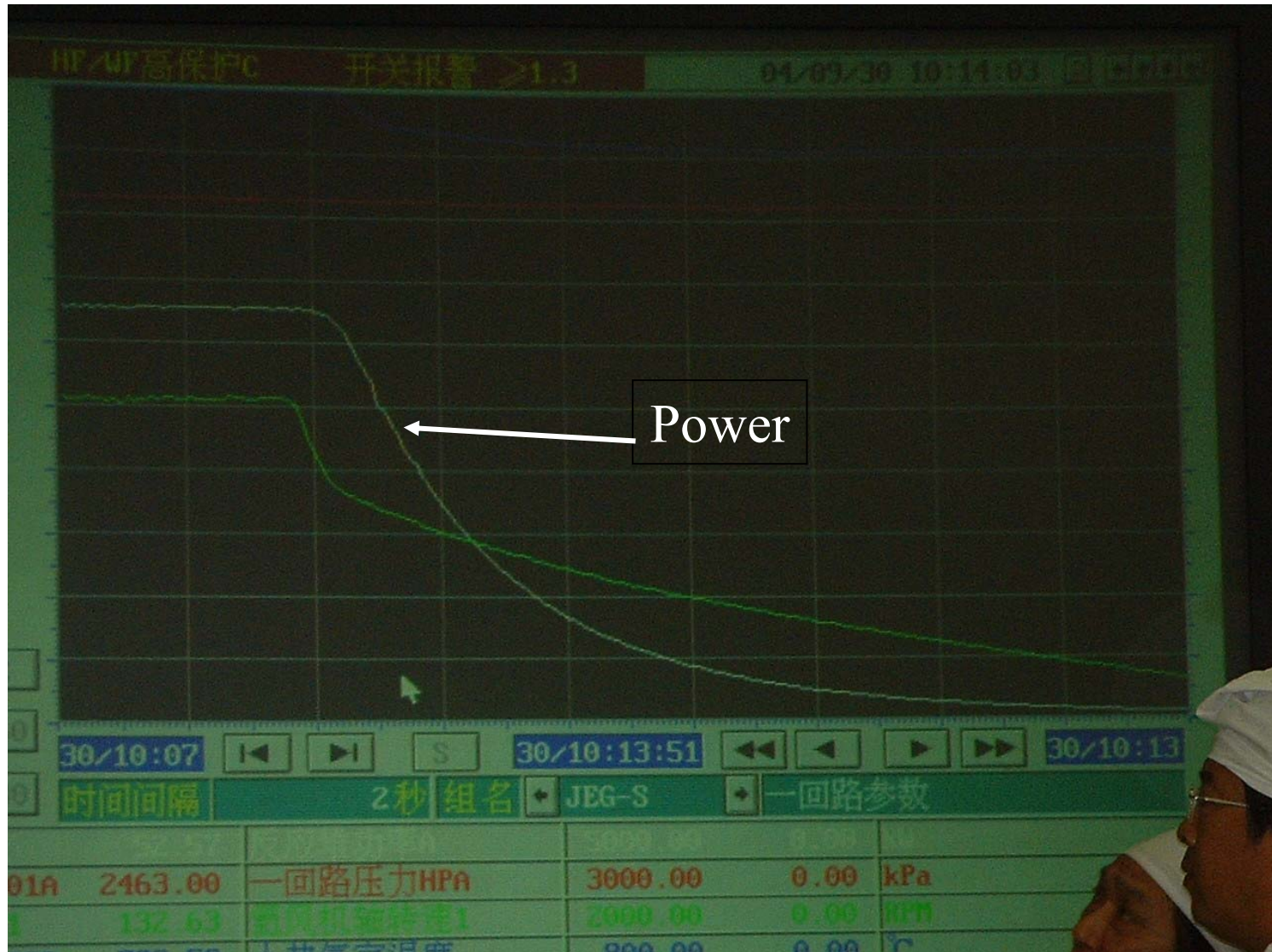

# Loss of Cooling Test

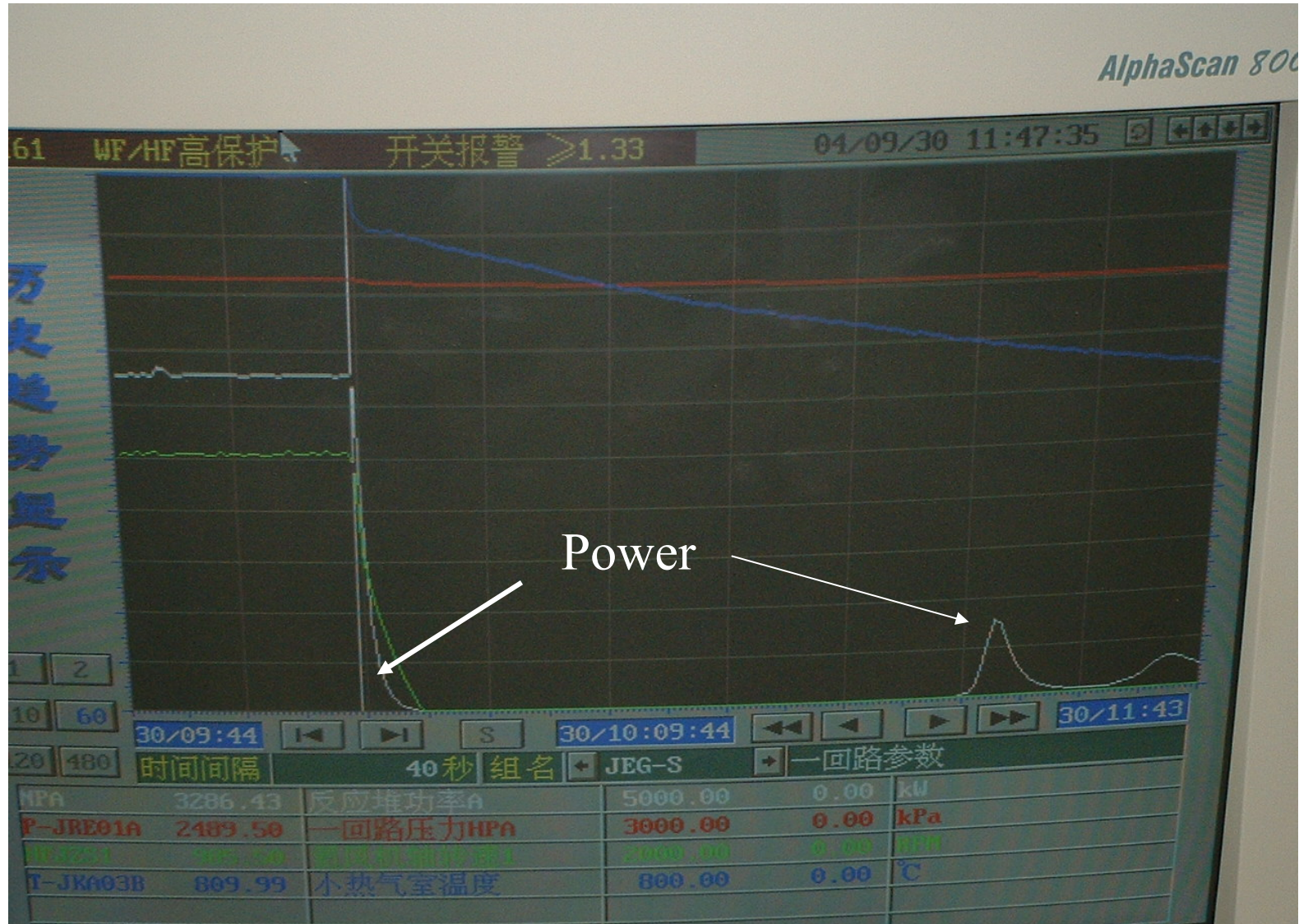

# International Activities

## Countries with Active HTGR Programs

- China - 10 MWth Pebble Bed - 2000 critical
- Japan - 40 MWth Prismatic
- South Africa - 400 MWth Pebble - 2012
- Russia - 290 MWe - Pu Burner Prismatic  
2007 (GA, Framatome, DOE, etc)
- Netherlands - small industrial Pebble
- Germany (past) - 300 MWe Pebble Operated
- MIT - 250 MWth - Intermediate Heat Exch.

# **Pebble Bed Modular Reactor**

## **South Africa**

- 165 MWe Pebble Bed Plant - ESKOM
- Direct Helium High Temperature Cycle
- In Licensing Process
- Schedule for construction start 2007
- Operation Date 2011/12
- Commercial Reference Plant

# South Africa Demonstration Plant Status

---

- **Koeberg site on Western Cape selected**
- **Designated national strategic project in May 2003**
- **Environmental Impact Assessment (EIA) completed with positive record of decision; appeals to be dispositioned by December 2004**
- **Revised Safety Analysis Report in preparation; to be submitted to National Nuclear Regulator in January 2006**
- **Construction scheduled to start April 2007 with initial operation in 2010**
- **Project restructuring ongoing with new investors and new governance**

# Commercial Plant Target Specifications

- **Rated Power per Module** 165-175 MW(e) depending on injection temperature
- **Eight-pack Plant** 1320 MW(e)
- **Module Construction (1st) Schedule** 24 months
- **Planned Outages** 30 days per 6 years
- **Fuel Costs & O&M Costs** < 9 mills/kWh
- **Availability** >95%

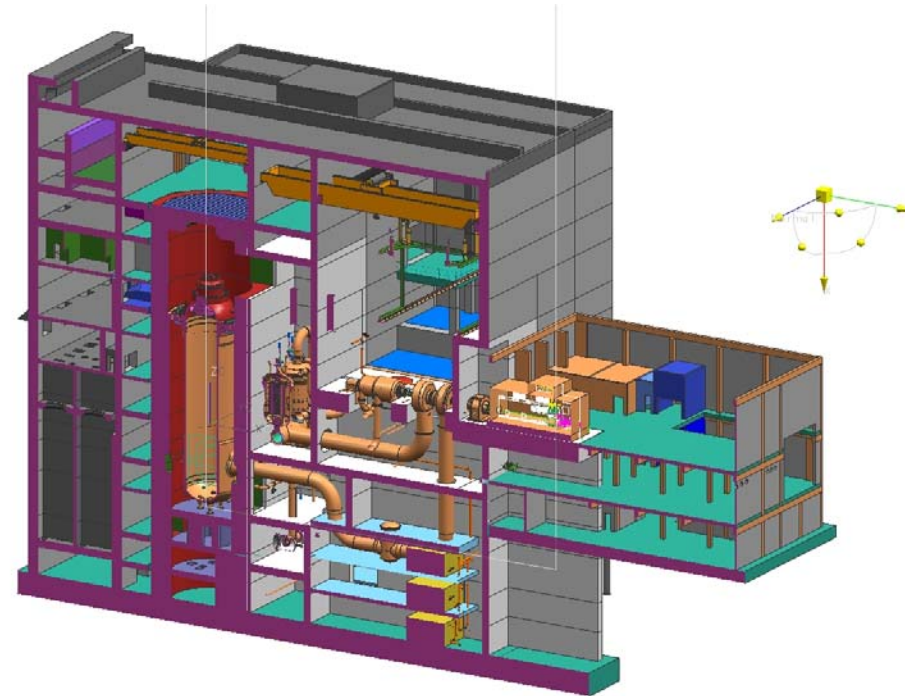

# Modular High Temperature Gas Reactor

## Russia

- General Atomics Design
- 290 MWe - Prismatic Core
- Excess Weapons Plutonium Burner
- In Design Phase in Russia
- Direct Cycle
- Start of Construction – Depends on US Gov Funding – maybe never

# High Temperature Test Reactor

## Japan

- 40 MWth Test Reactor
- First Critical 1999
- Prismatic Core
- Intermediate Heat Exchangers
- Reached full power and 950 C for short time

# High Temperature Test Reactor



# High Temperature Test Reactor (HTTR)

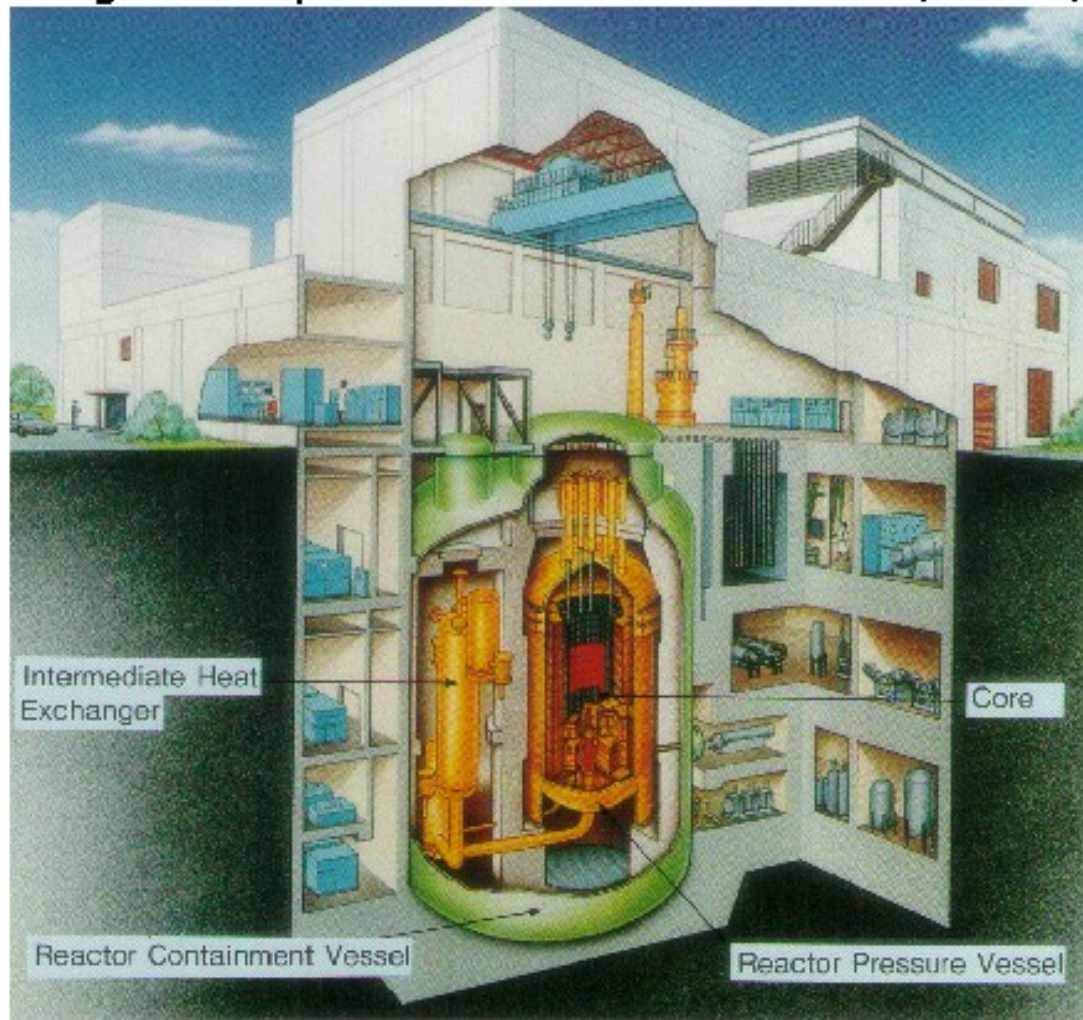

# R&D Programs on Gas Turbine Power Conversion System

## Gas Turbine System Test

Operation & Control  
(2003-2010)

## Compressor Model Test

Aerodynamic performance  
(2001-2004)

## Recuperator development

(-2003)



## Design study on the GTHTR300

Reactor design, PCU design, Safety design  
(2001-2007)

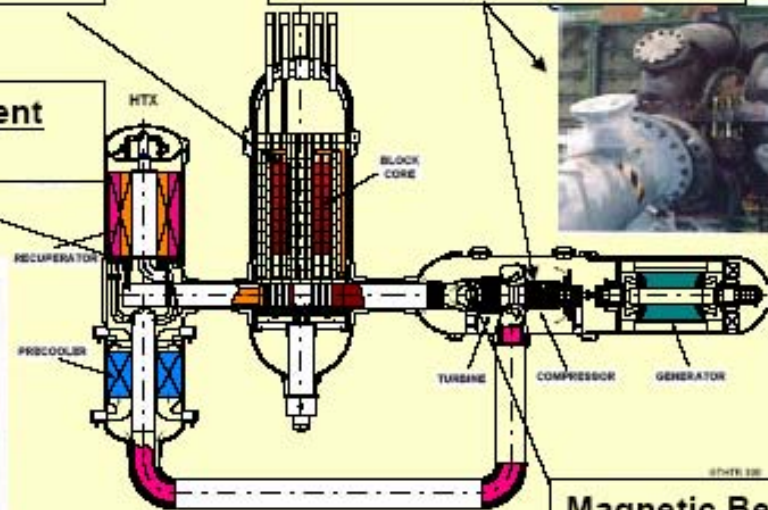

## Magnetic Bearing Test

Rotor dynamics  
(2002-2007)



# High Temperature Reactor

## China

- 10 MWth - 4 MWe Electric Pebble Bed
- Initial Criticality Dec 2000
- Intermediate Heat Exchanger - Steam Cycle
- Using to as test reactor for full scale demonstration plant – HTR-PM

# HTR- 10 China

## First Criticality Dec.1, 2000



# Main parameters of HTR-PM

Reactor thermal power	MW	371
Active core diameter/height	m	2.00-4.00/9.43
Average power density	MW/m <sup>3</sup>	4.28
Primary helium pressure	MPa	7.0
Helium inlet temperature	°C	250
Helium outlet temperature	°C	750
Helium mass flow rate	Kg/s	145
Fuel		UO <sub>2</sub>
U-235 enrichment of fresh fuel elements	%	8.77
Diameter of spherical fuel elements	mm	60
Number of spherical fuel elements	ball	479358
Number of graphite balls	ball	159786
Average discharge burnup	MWd/tU	80,000

## **Roles of HTGRs in China**

- **Supplement of nuclear power generation for densely and sparsely populated regions**
- **Providing process steam for heavy oil recovery and petrochemical industry**
- **As process heat resource for coal gasification and liquefaction as well as hydrogen production**

**HTR-PM  
with the steam  
turbine cycle**

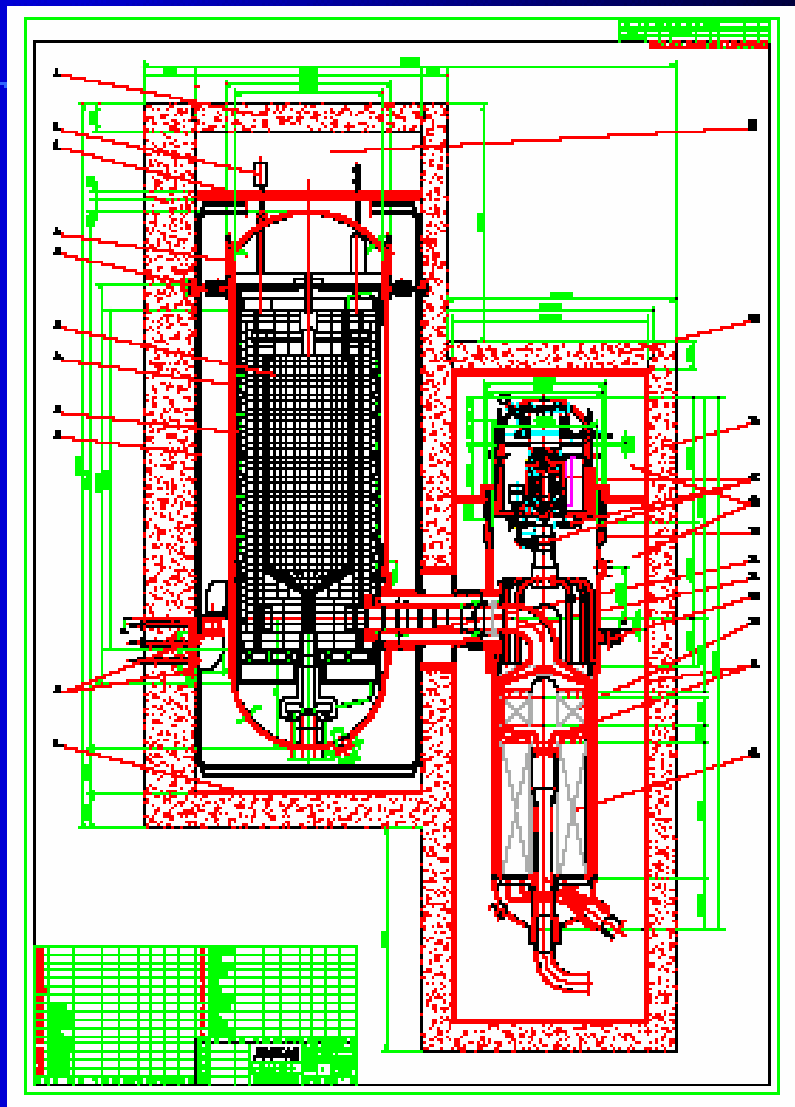

# China is Focused

- Formed company – Chinergy
  - Owned by Institute of Nuclear Energy Technology of Tsinghua University and China Nuclear Engineering Company (50/50)
  - Customer – Huaneng Group – largest utility
- Two Sites selected – evaluating now
- Target commercial operation 2010/2011

# France – AREVA - Framatome

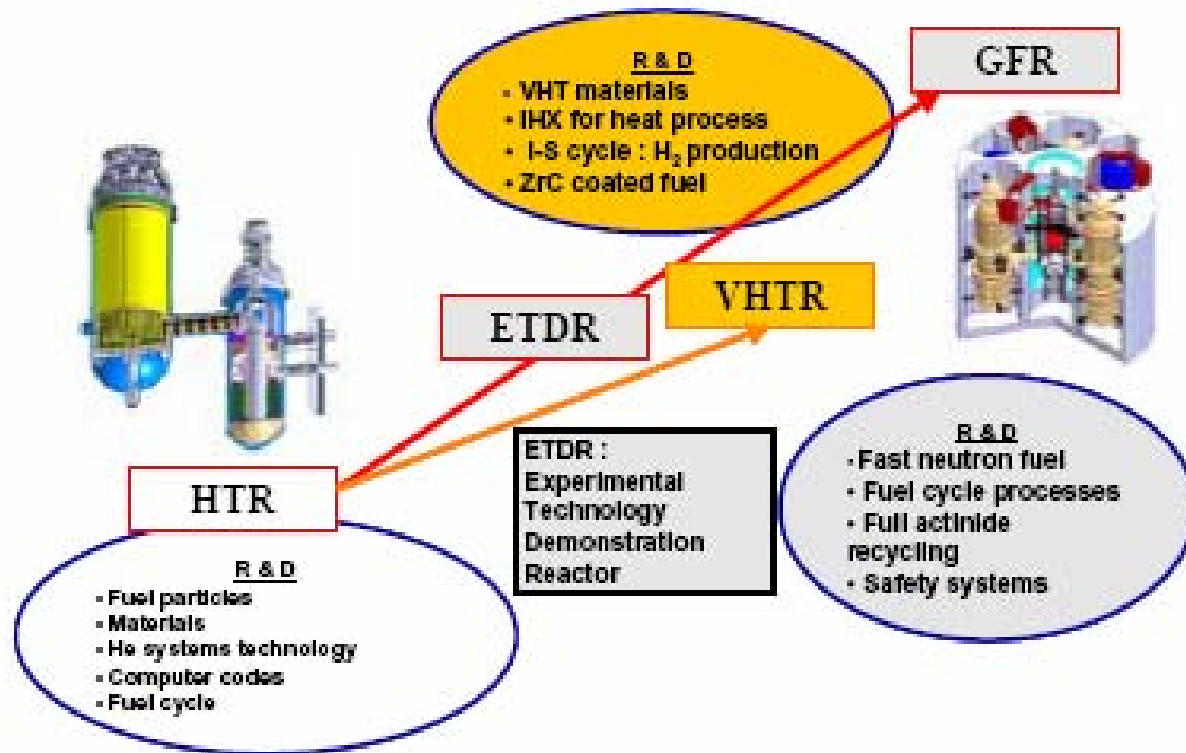
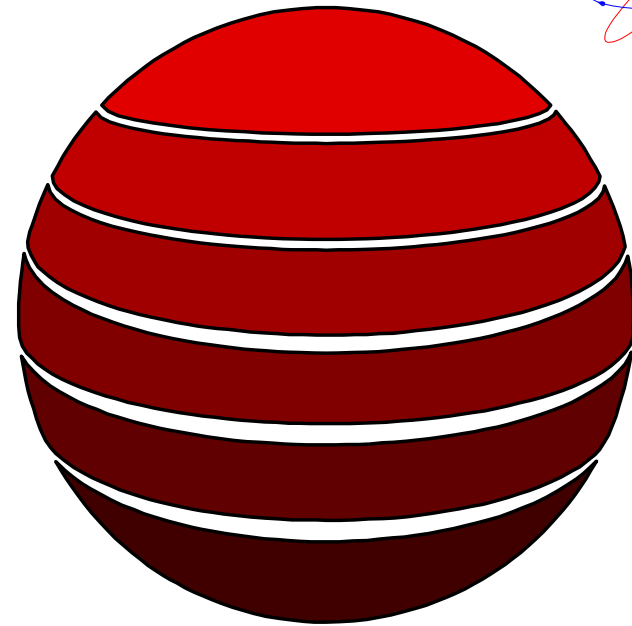

FIGURE 1: "Gas Technology Path" for a sequenced development of high temperature gas cooled reactors.

# MIT's Pebble Bed Project

- Similar in Concept to ESKOM
- Developed Independently
- Indirect Gas Cycle
- Costs 3.3 c/kwhr
- High Automation
- License by Test



# Modular High Temperature Pebble Bed Reactor

- 120 MWe
- Helium Cooled
- 8 % Enriched Fuel
- Built in 2 Years
- Factory Built
- Site Assembled
- On--line Refueling
- Modules added to meet demand.
- No Reprocessing
- High Burnup  
>90,000 Mwd/MT
- Direct Disposal of HLW
- Process Heat Applications -  
Hydrogen, water

# MIT MPBR Specifications

<b>Thermal Power</b>	<b>250 MW - 115 Mwe</b>
<b>Target Thermal Efficiency</b>	<b>45 %</b>
Core Height	10.0 m
Core Diameter	3.5 m
Pressure Vessel Height	16 m
Pressure Vessel Radius	5.6 m
<b>Number of Fuel Pebbles</b>	<b>360,000</b>
Microspheres/Fuel Pebble	11,000
Fuel	UO <sub>2</sub>
Fuel Pebble Diameter	60 mm
Fuel Pebble enrichment	8%
Uranium Mass/Fuel Pebble	7 g
<b>Coolant</b>	<b>Helium</b>
Helium mass flow rate	120 kg/s (100% power)
<b>Helium entry/exit temperatures</b>	<b>450°C/850°C</b>
Helium pressure	80 bar
<b>Mean Power Density</b>	<b>3.54 MW/m<sup>3</sup></b>
Number of Control Rods	6

# For 1150 MW Combined Heat and Power Station

## Ten-Unit VHTR Plant Layout (Top View)

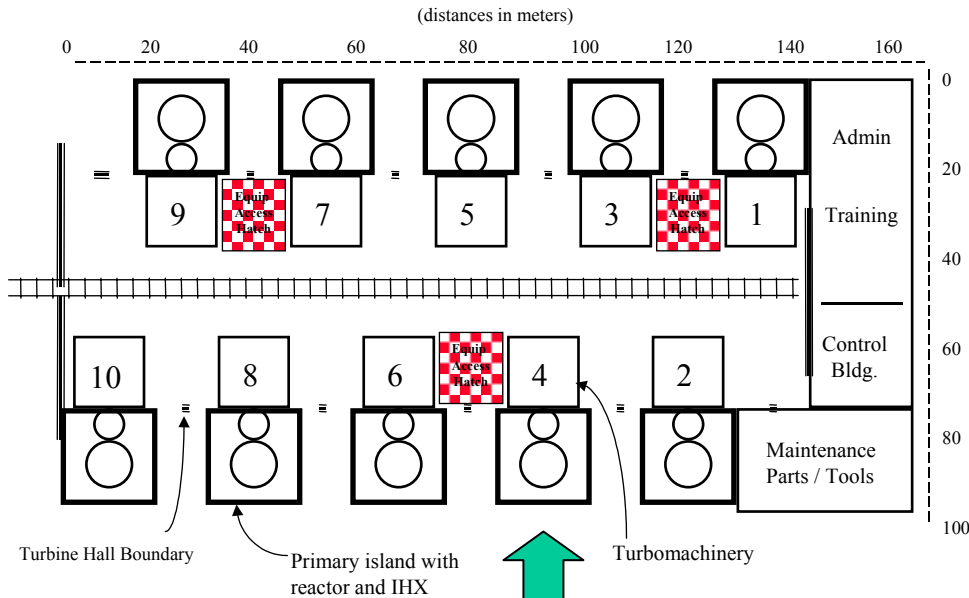

### VHTR Characteristics

- Temperatures  $> 900\text{ C}$
- Indirect Cycle
- Core Options Available
- Waste Minimization

Oil Refinery



Hydrogen Production



Desalinization Plant

# Reference Plant

## Modular Pebble Bed Reactor

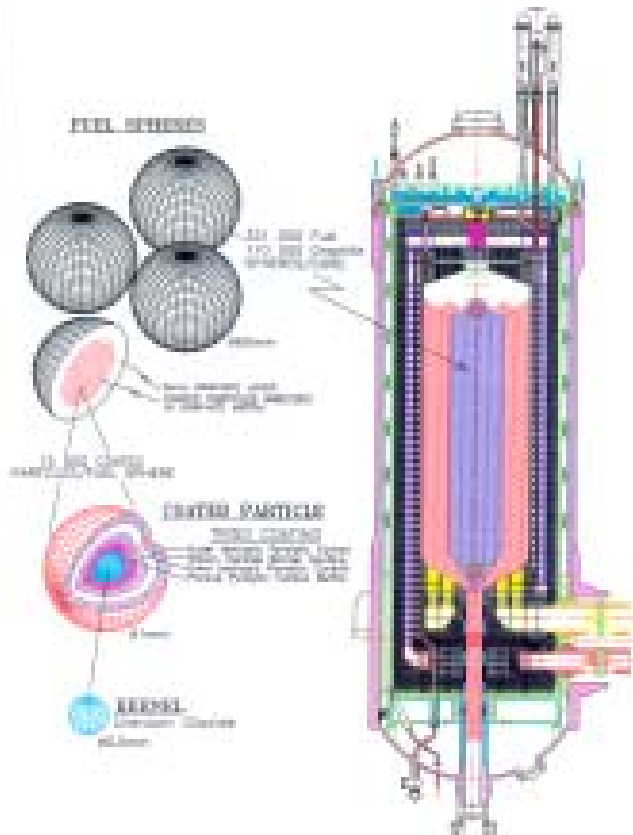

<b>Thermal Power</b>	<b>250 MW</b>
<b>Core Height</b>	<b>10.0 m</b>
<b>Core Diameter</b>	<b>3.5 m</b>
<b>Fuel</b>	<b>UO<sub>2</sub></b>
<b>Number of Fuel Pebbles</b>	<b>360,000</b>
<b>Microspheres/Fuel Pebble</b>	<b>11,000</b>
<b>Fuel Pebble Diameter</b>	<b>60 mm</b>
<b>Microsphere Diameter</b>	<b>~ 1mm</b>
<b>Coolant</b>	<b>Helium</b>

# Video Demo



19.mpg



20.mpg



21.mpg



22.mpg



23.mpg



# Shaping Ring for Central Column Formation

- Shaping ring used to form central column at top 3 inches
- Rest open - no ring
- Column maintained during slow drain down.

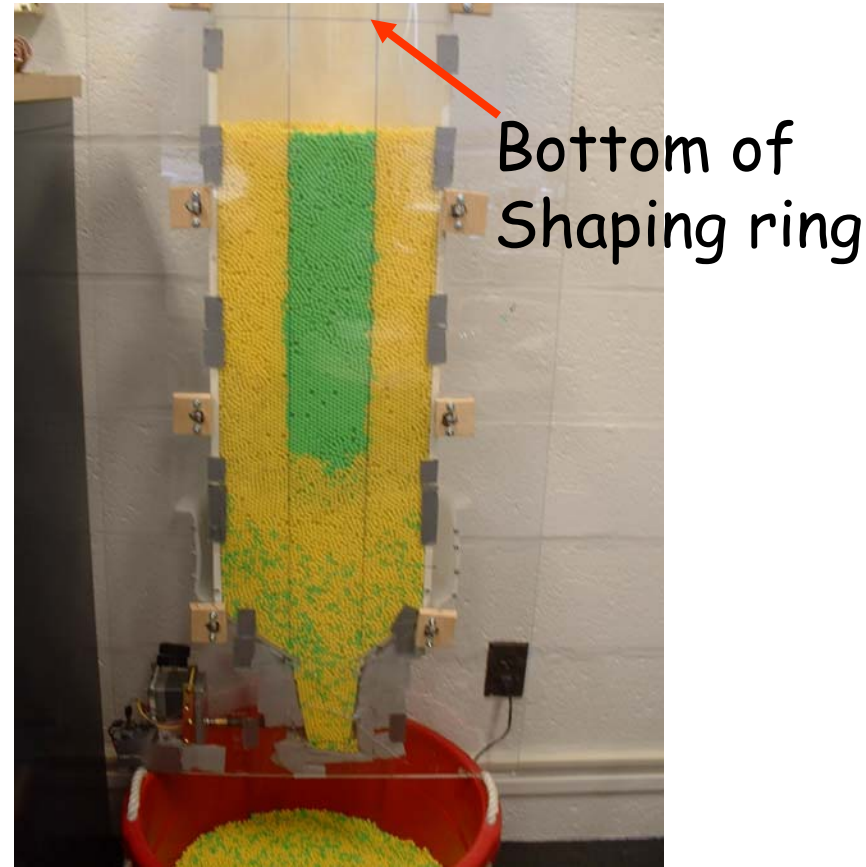

# Features of Current Design

Thermal Power	250 MW
Gross Electrical Power	132.5 MW
Net Electrical Power	120.3 MW
Plant Net Efficiency	48.1% (Not take into account cooling IHX and HPT. if considering, it is believed > 45%)
Helium Mass flowrate	126.7 kg/s
Core Outlet/Inlet T	900°C/520°C
Cycle pressure ratio	2.96
Power conversion unit	Three-shaft Arrangement

# Indirect Cycle with Intermediate Helium to Helium Heat Exchanger

## Current Design Schematic

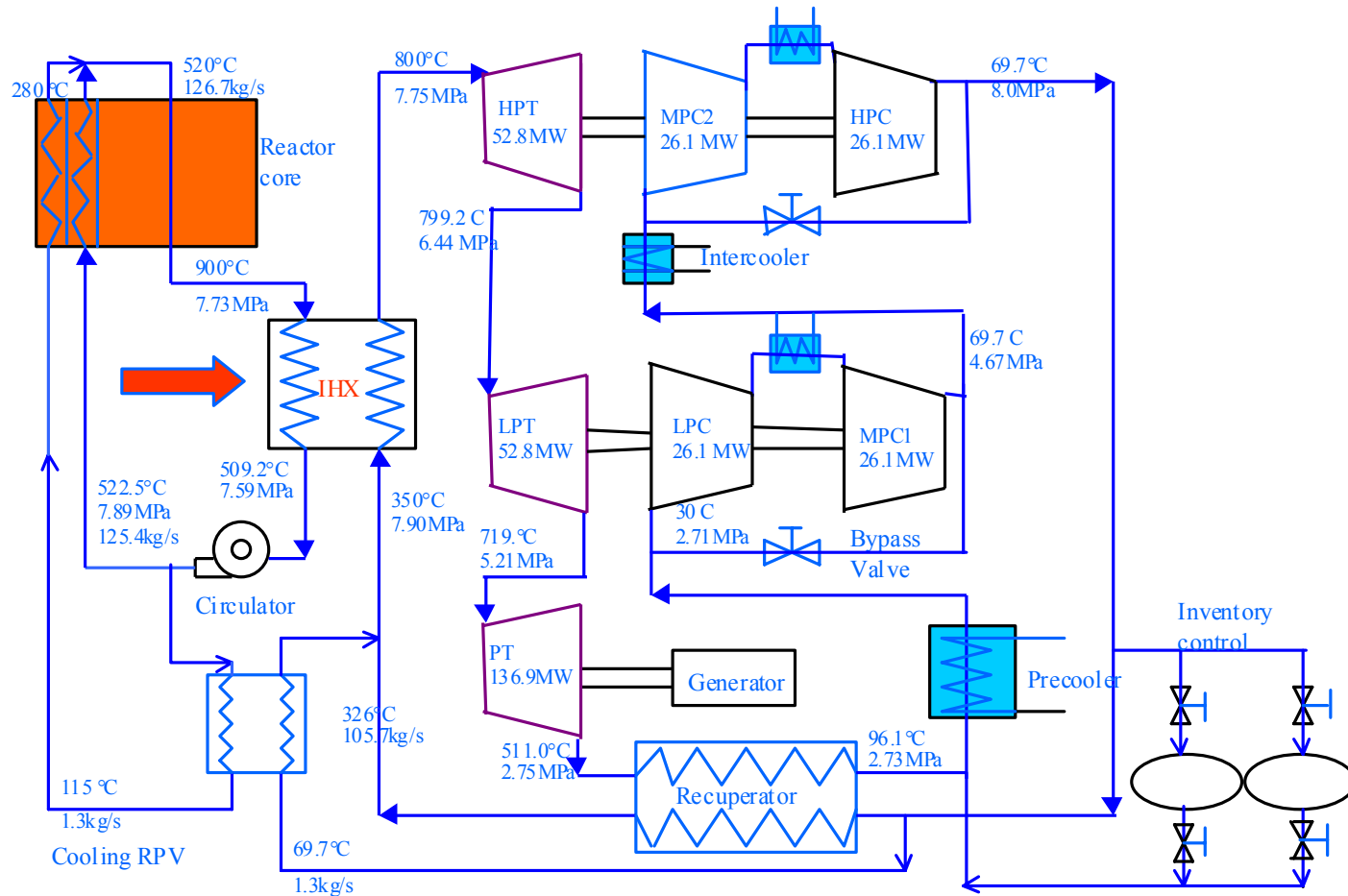

# Top Down View of Pebble Bed Reactor Plant

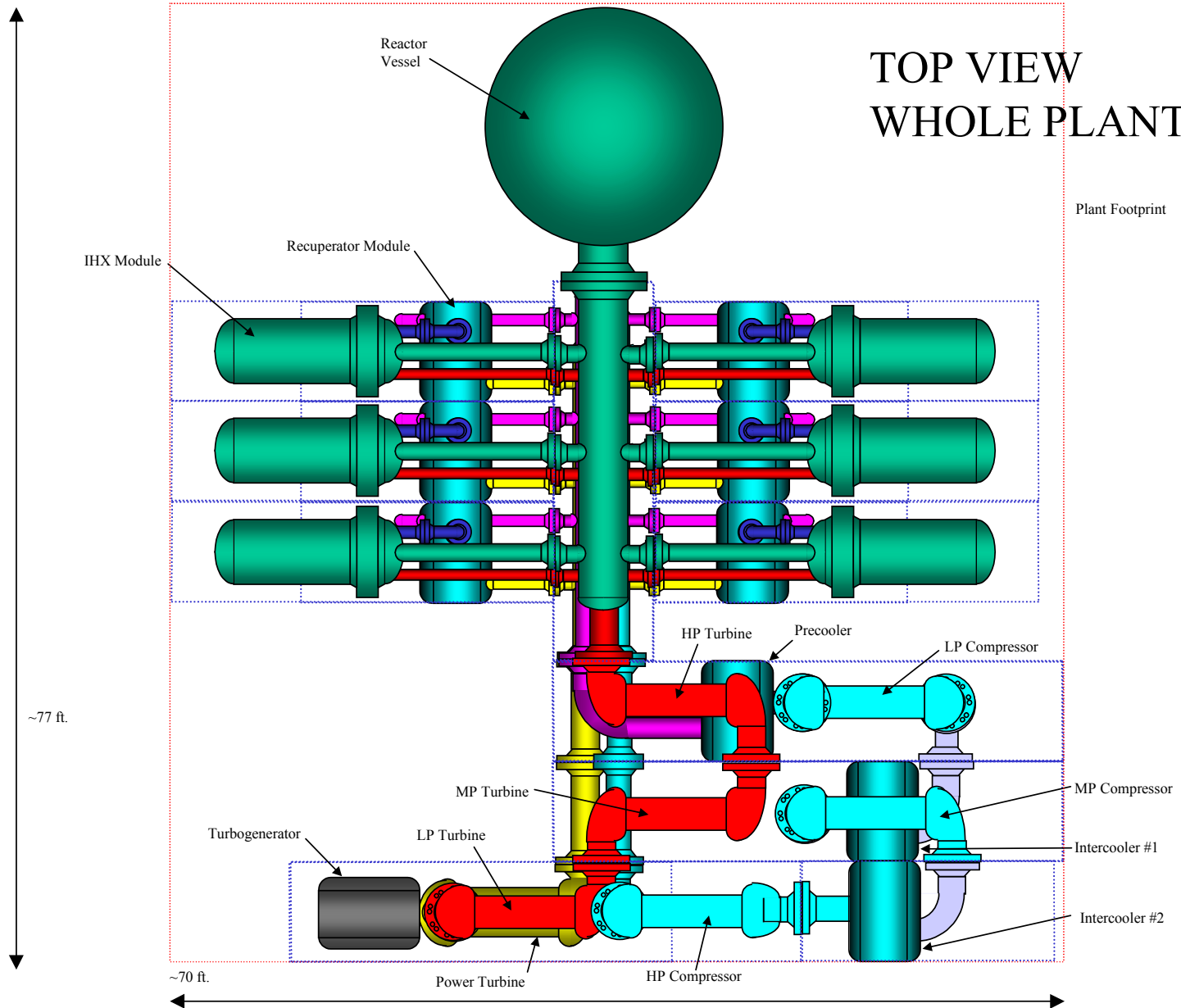

# PLANT MODULE SHIPPING BREAKDOWN

Total Modules Needed For Plant Assembly (21): Nine 8x30 Modules, Five 8x40 Modules, Seven 8x20 Modules

Six 8x30 IHX Modules

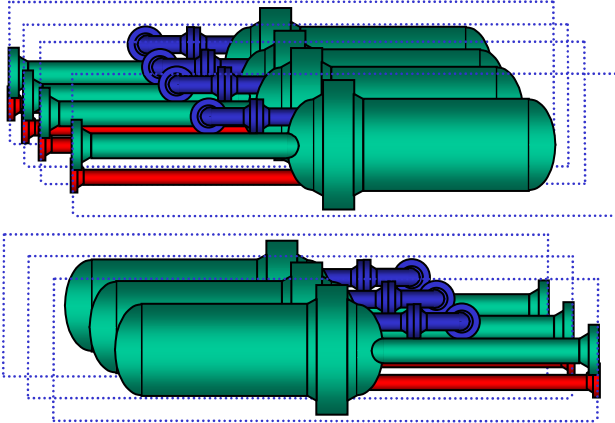

Six 8x20 Recuperator Modules

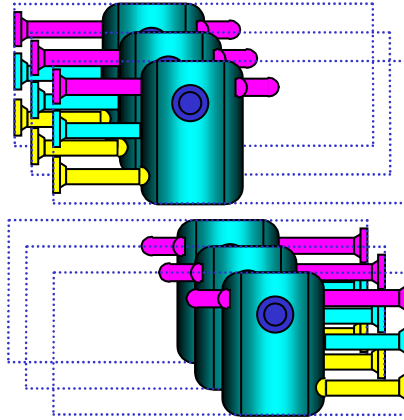

8x30 Power Turbine Module

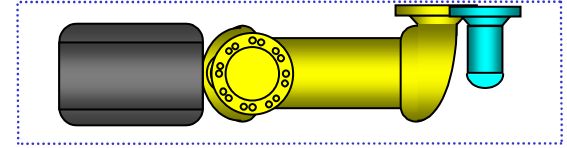

8x20 Intercooler #2 Module

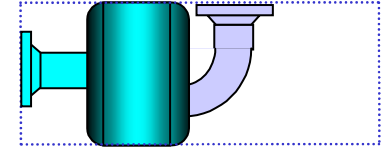

8x40 Piping and Precooler Module

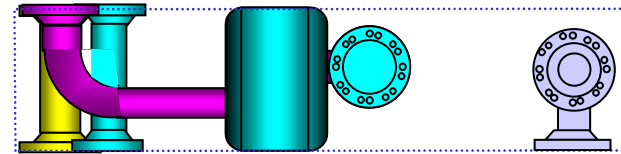

8x30 Upper Manifold Module

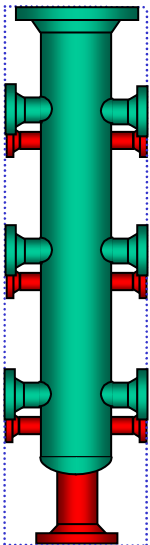

8x30 Lower Manifold Module

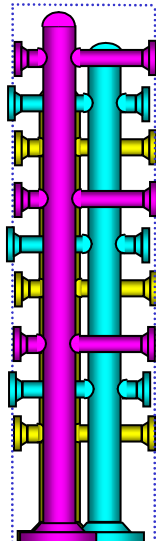

8x40 Piping & Intercooler #1 Module

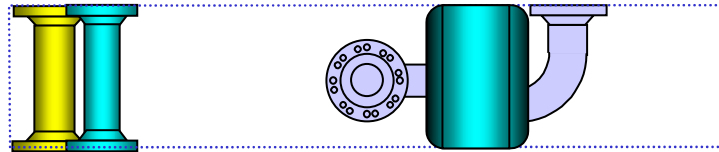

8x40 HP Turbine, LP Compressor Module

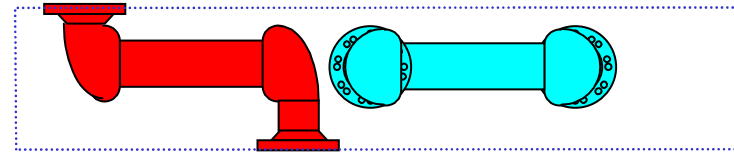

8x40 MP Turbine, MP Compressor Module

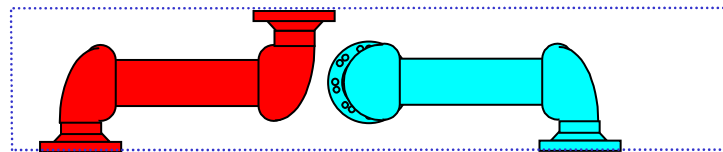

8x40 LP Turbine, HP Compressor Module

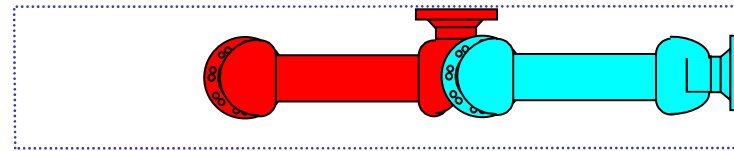

# Example Plant Layout

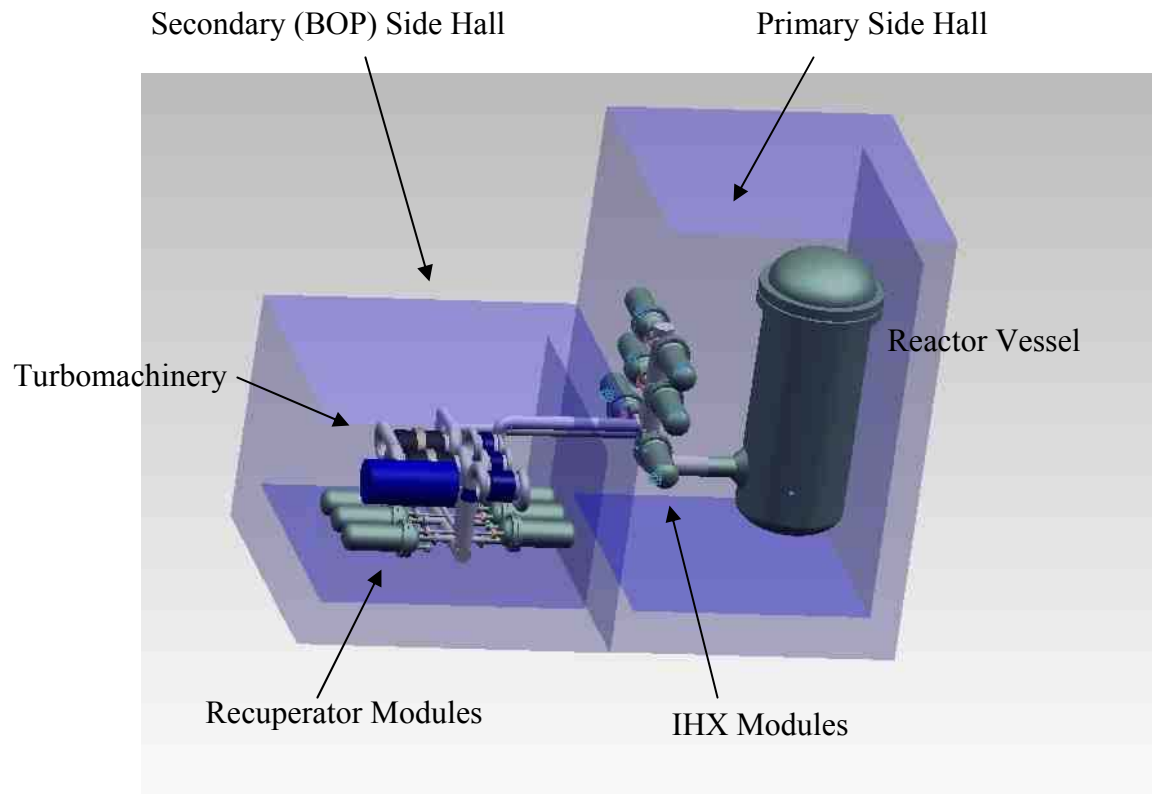

NOTE: Space-frames and ancillary components  
not shown for clarity

# Space Frame Technology for Shipment and Assembly

Everything is installed in the volume occupied by the space frame - controls, wiring, instrumentation, pumps, etc.

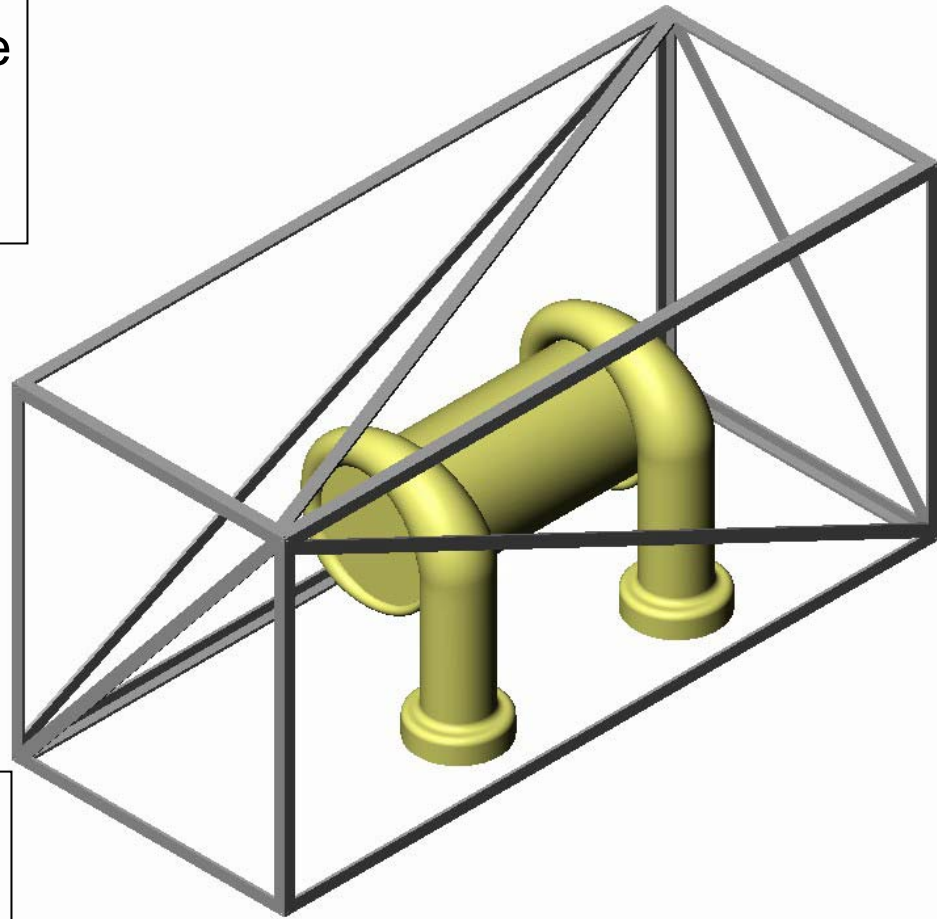

Each space frame will be “plugged” into the adjacent space frame.

# “Lego” Style Assembly in the Field



# Space-Frame Concept

- **Standardized Frame Size**
- **2.4 x 2.6 x 3(n) Meter**
- Standard Dry Cargo Container
- Attempt to Limit Module Mass to ~30t / 6m
  - ISO Limit for 6m Container
  - Stacking Load Limit ~190t
  - ISO Container Mass ~2200kg
  - Modified Design for Higher Capacity—~60t / 12m module
- Overweight Modules
  - Generator (150-200t)
  - Turbo-Compressor (45t)
  - Avoid Separating Shafts!
  - Heavy Lift Handling Required
  - Dual Module (12m / 60t)
- Stacking Load Limit Acceptable
  - Dual Module = ~380T
  - Turbo-generator Module <300t
- Design Frame for Cantilever Loads
  - Enables Modules to be Bridged
- **Space Frames are the structural supports for the components.**
- **Only need to build open vault areas for space frame installation - RC & BOP vault**
- Alignment Pins on Module Corners
  - High Accuracy Alignment
  - Enables Flanges to be Simply Bolted Together
- Standardized Umbilical Locations
  - Bus-Layout of Generic Utilities (data/control)

# Present Layout

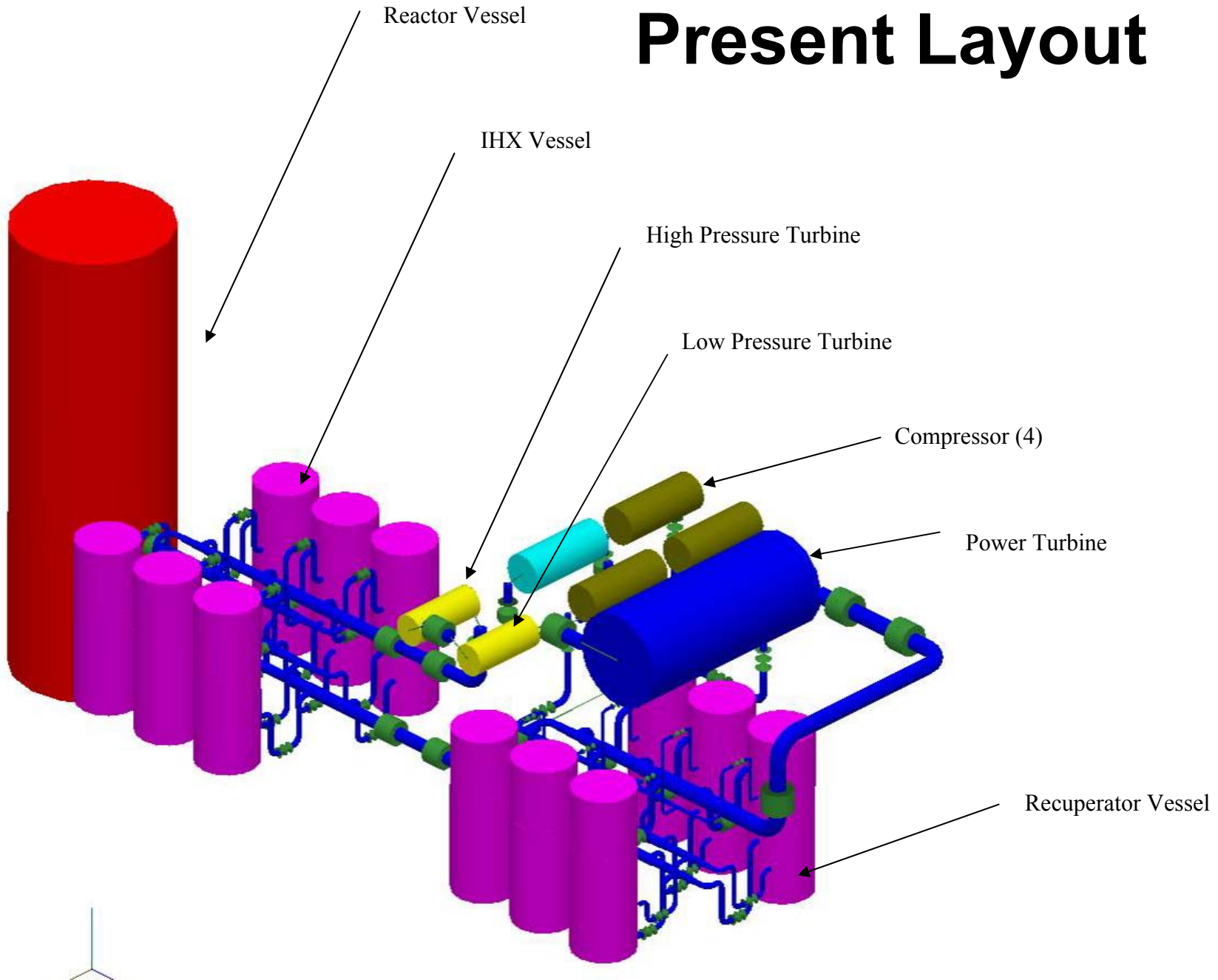

# Main IHX Header Flow Paths

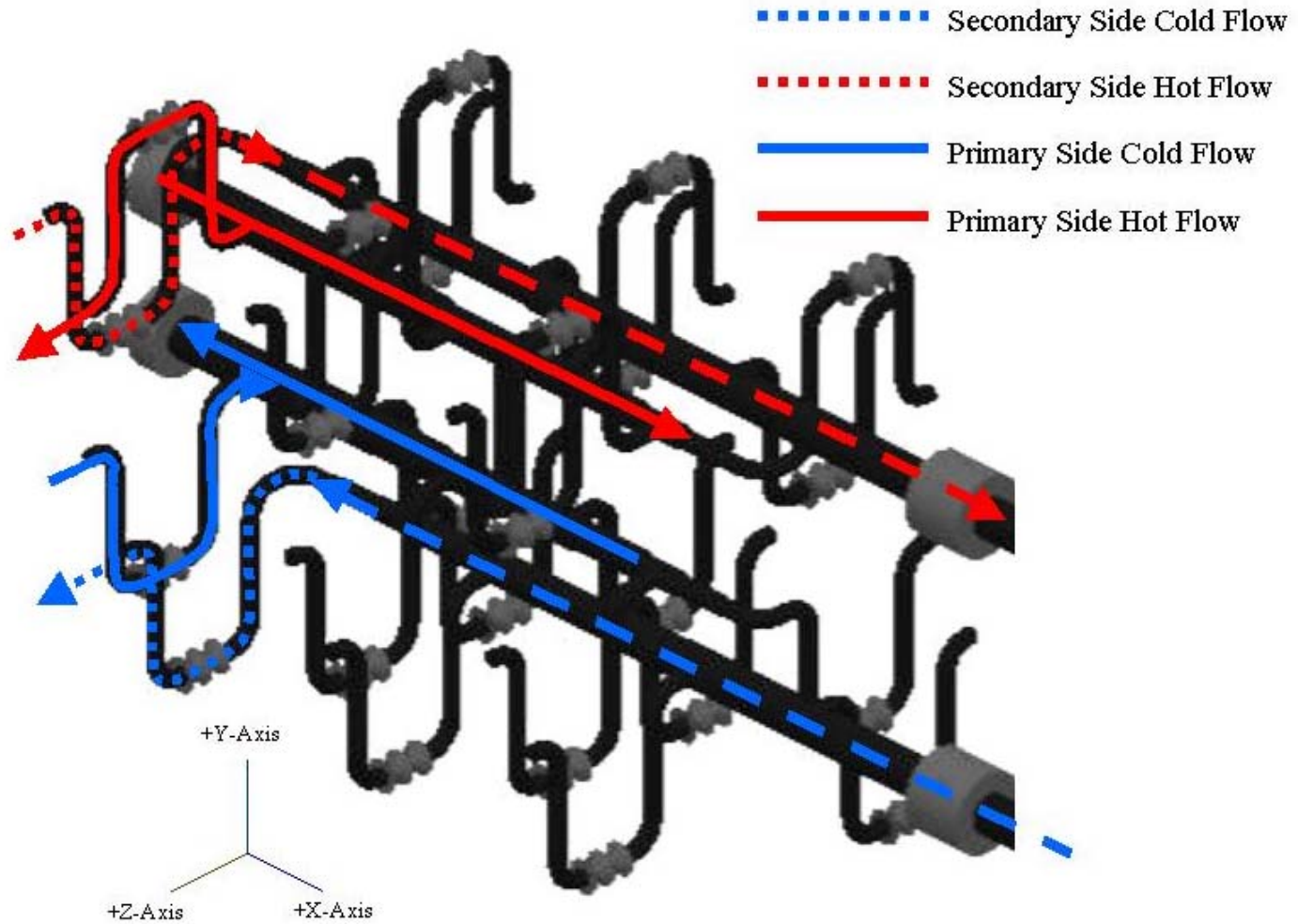

# Plant With Space Frames

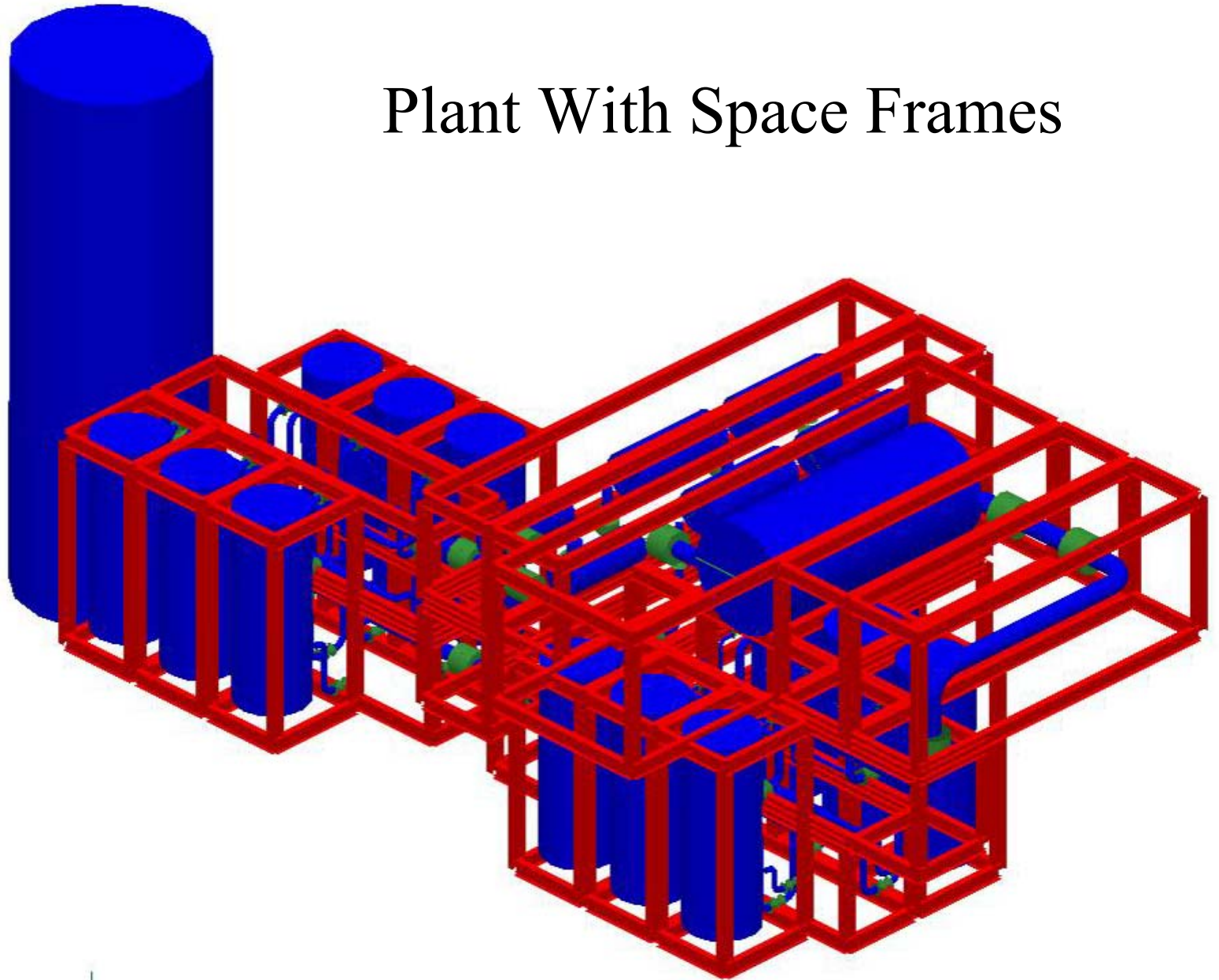

# Upper IHX Manifold in Spaceframe

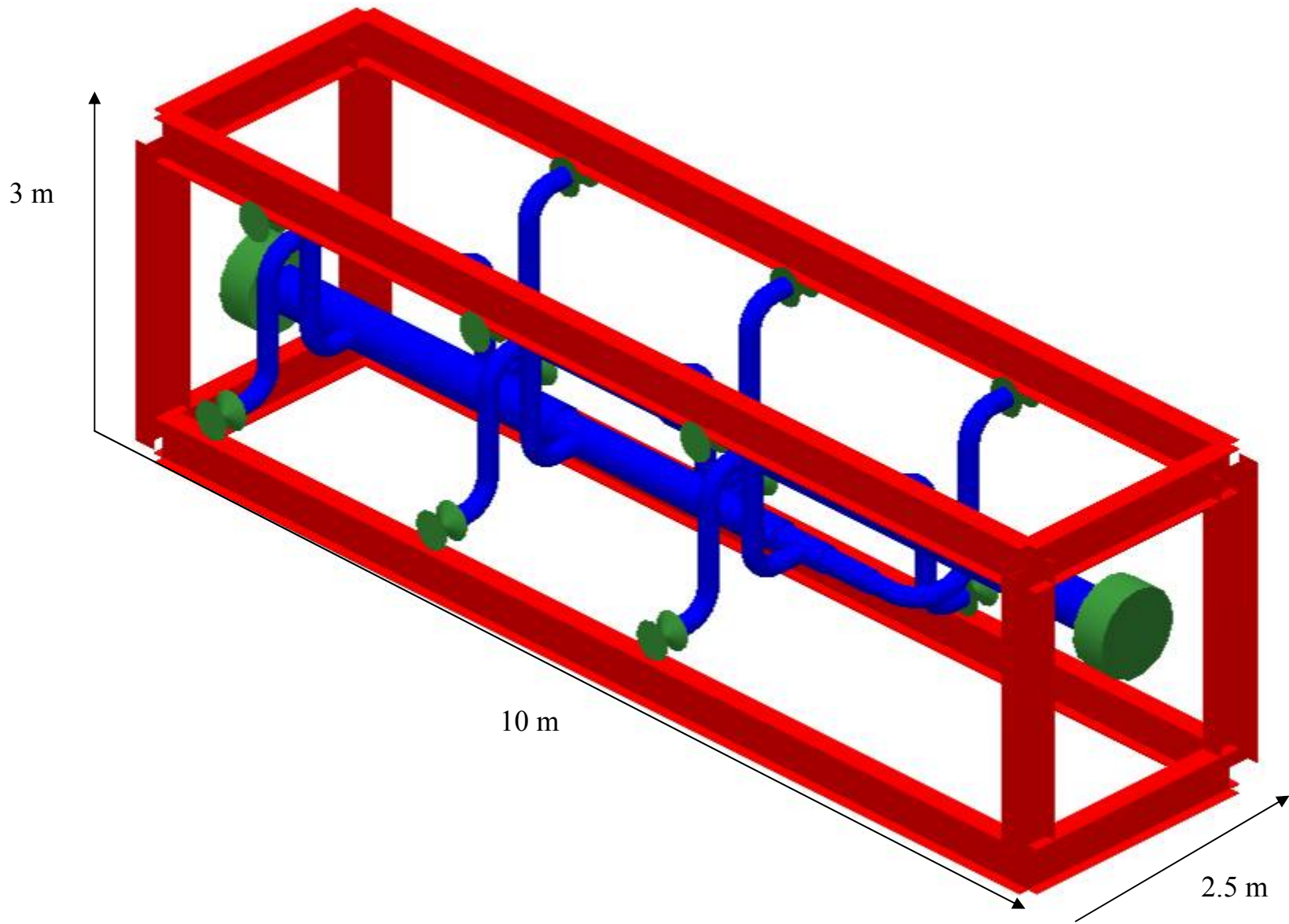

# Distributed Production Concept

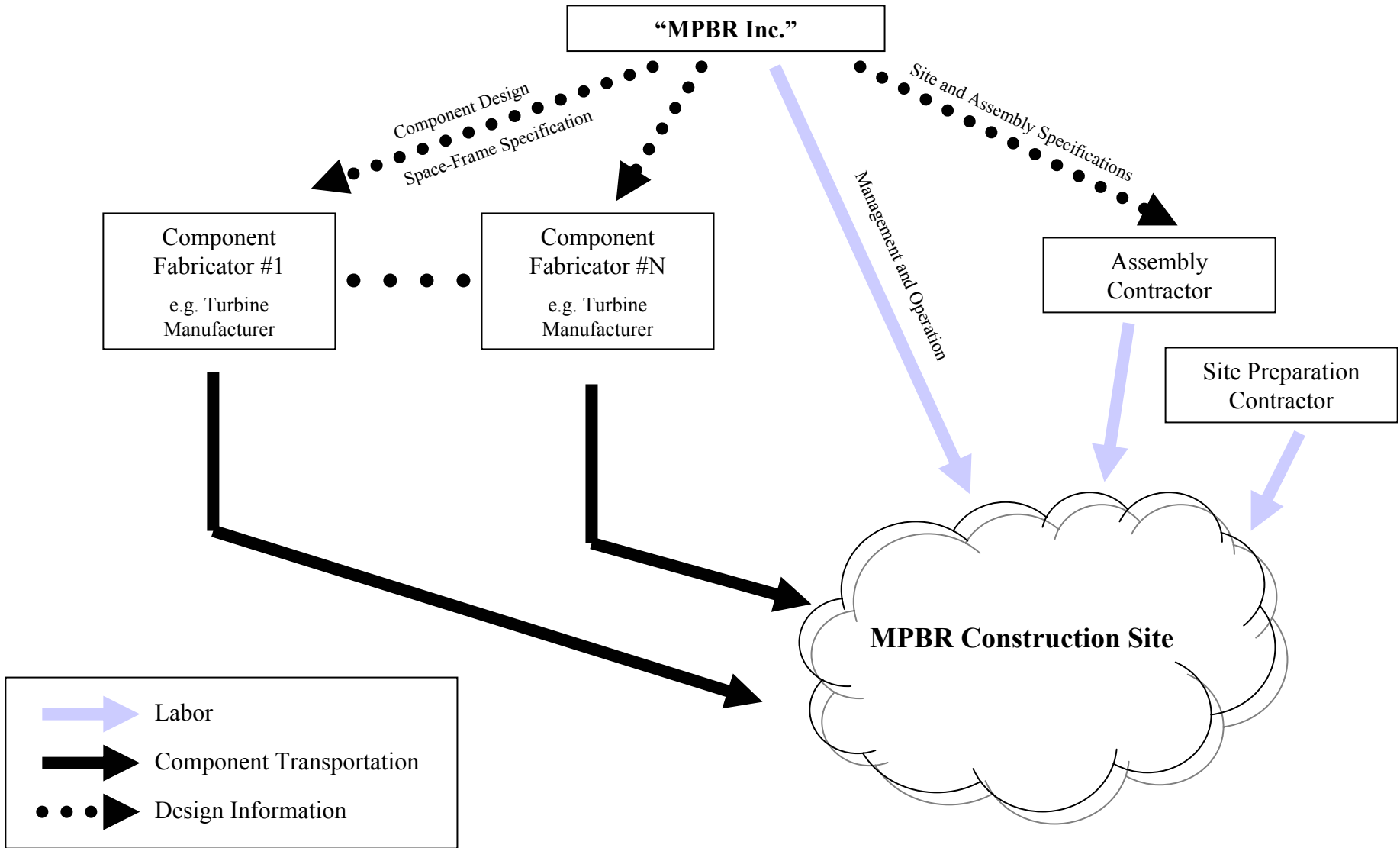

# Generating Cost

## PBMR vs. AP600, AP1000, CCGT and Coal

(Comparison at 11% IRR for Nuclear Options, 9% for Coal and CCGT<sup>1</sup>)

(All in ¢/kWh)

	<u>AP600</u>	<u>AP1000 @</u>		<u>PBMR</u>	<u>Coal<sup>2</sup></u>		<u>CCGT @ Nat. Gas = <sup>3</sup></u>			
		<u>3000Th</u>	<u>3400Th</u>		<u>'Clean'</u>	<u>'Normal'</u>	<u>\$3.00</u>	<u>\$3.50</u>	<u>\$4.00</u>	<u>\$5.00</u>
Fuel	0.5	0.5	0.5	<b>0.48</b>	0.6	0.6	2.1	2.45	2.8	3.5
O&M	0.8	0.52	0.46	<b>0.23</b>	0.8	0.6	0.25	0.25	0.25	0.25
Decommissioning	0.1	0.1	0.1	0.08	-	-	-	-	-	-
Fuel Cycle	<u>0.1</u>	<u>0.1</u>	<u>0.1</u>	<u>0.1</u>	-	-	-	-	-	-
Total Op Costs	1.5	1.22	1.16	<b>0.89</b>	1.4	1.2	2.35	2.70	3.05	3.75
Capital Recovery	<u>3.4</u>	<u>2.5</u>	<u>2.1</u>	<u>2.2</u>	<u>2.0</u>	<u>1.5</u>	<u>1.0</u>	<u>1.0</u>	<u>1.0</u>	<u>1.0</u>
Total	4.9	3.72	3.26	<b>3.09</b>	3.4	2.7	3.35	3.70	4.05	4.75

<sup>1</sup> All options exclude property taxes

<sup>2</sup> Preliminary best case coal options: "mine mouth" location with \$20/ton coal, 90% capacity factor & 10,000 BTU/kWh heat rate

<sup>3</sup> Natural gas price in \$/million Btu

# Next Generation Nuclear Plant

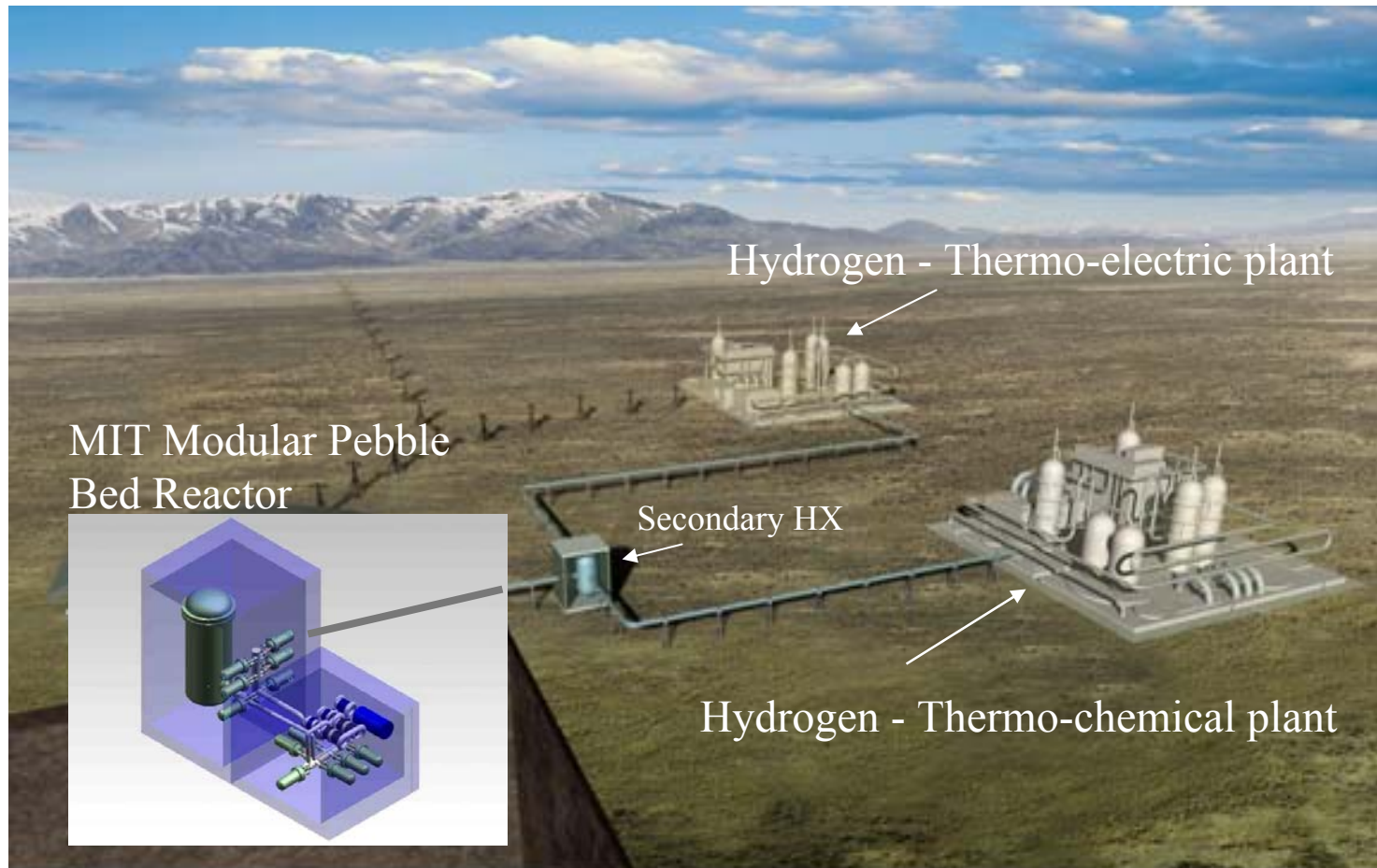

# Intermediate Heat Exchanger (IHX) Installed In Hot Pipe for PBMR NGNP

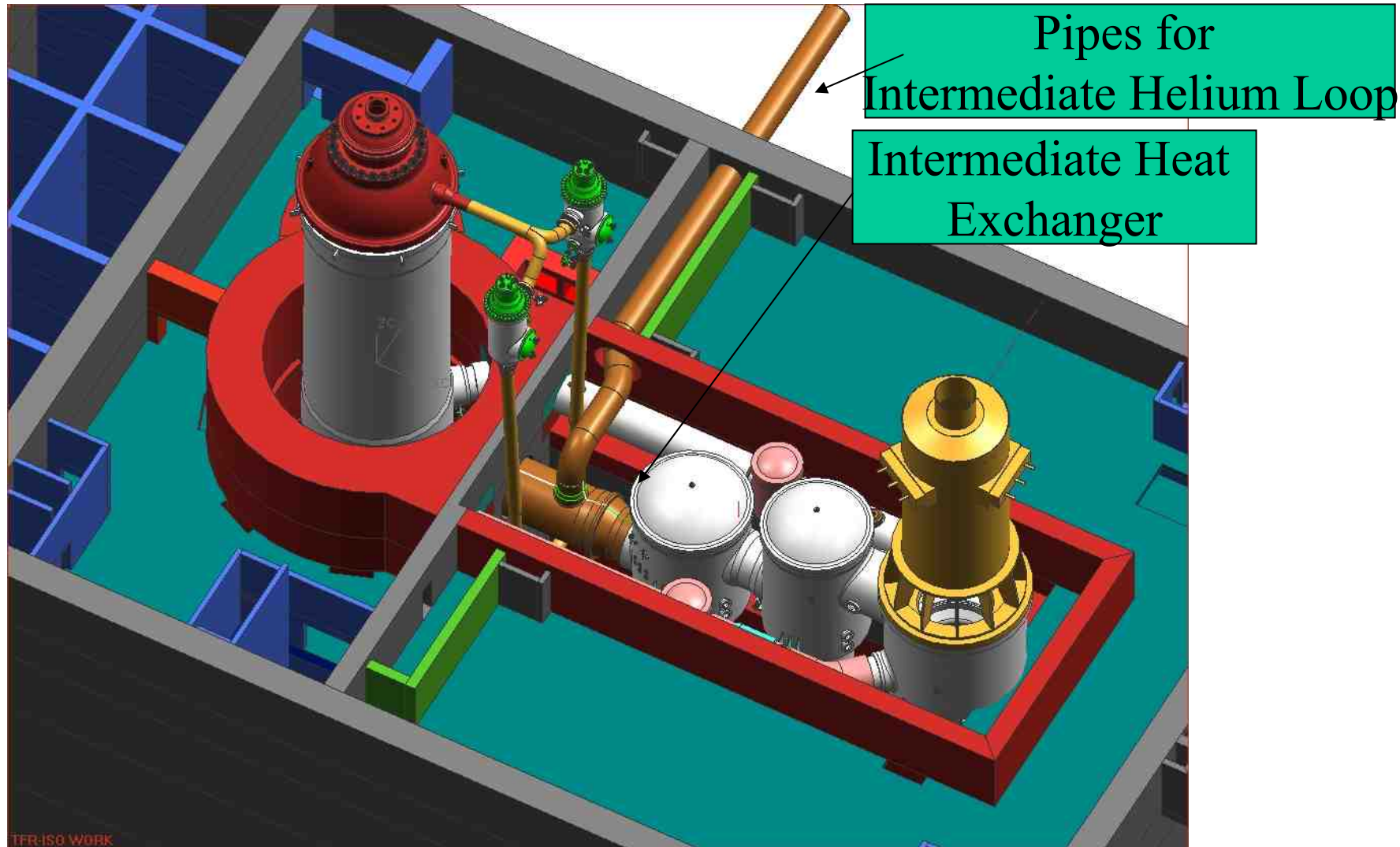

# Hydrogen Mission Modularity Flexibility

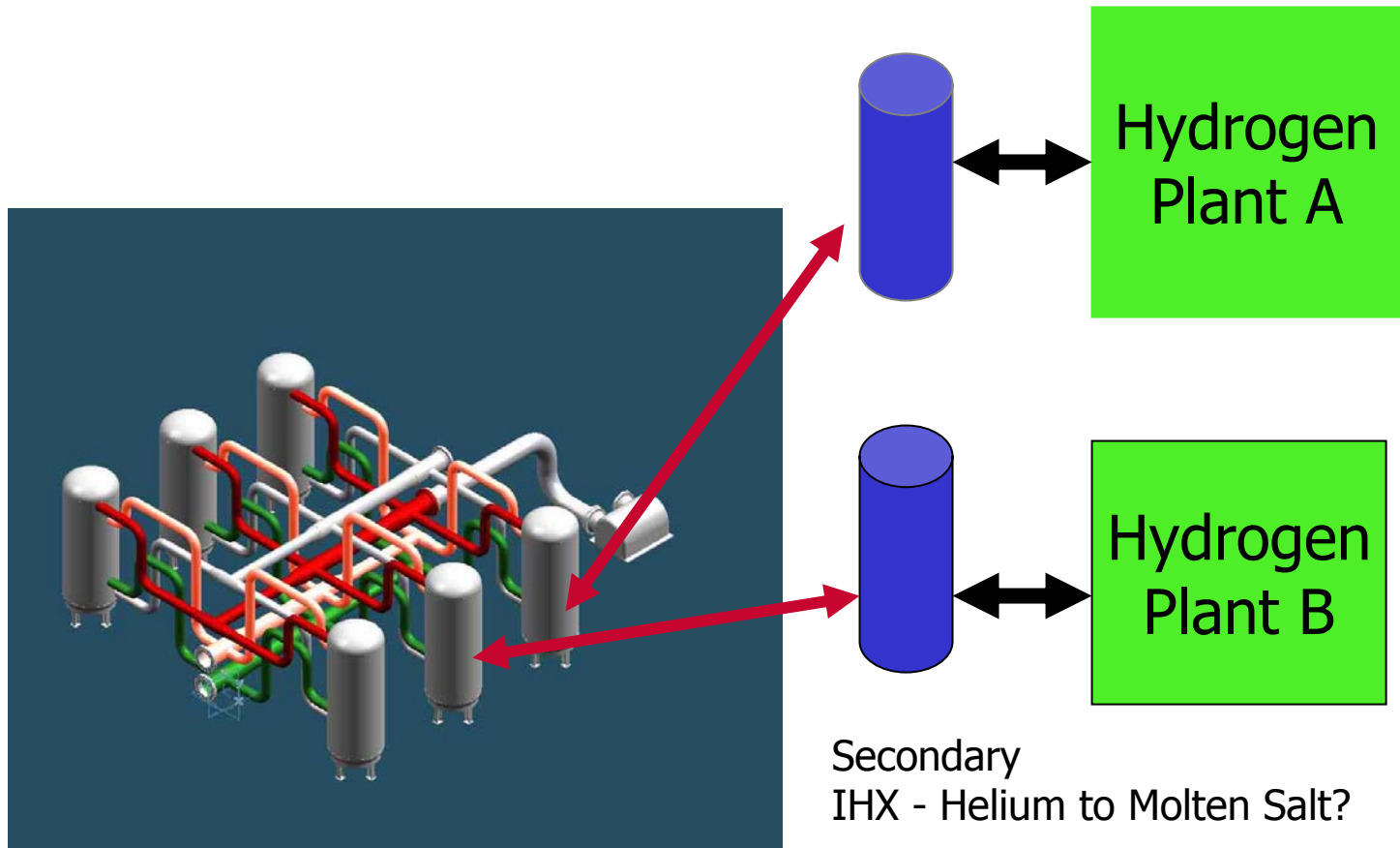

May use one or more IHX's from base electric plant for H<sub>2</sub>

# Primary Internals

- (3) Plate Fin Core Modules
- Core Modules Suspended to accommodate expansion



# VHTR Migration Path

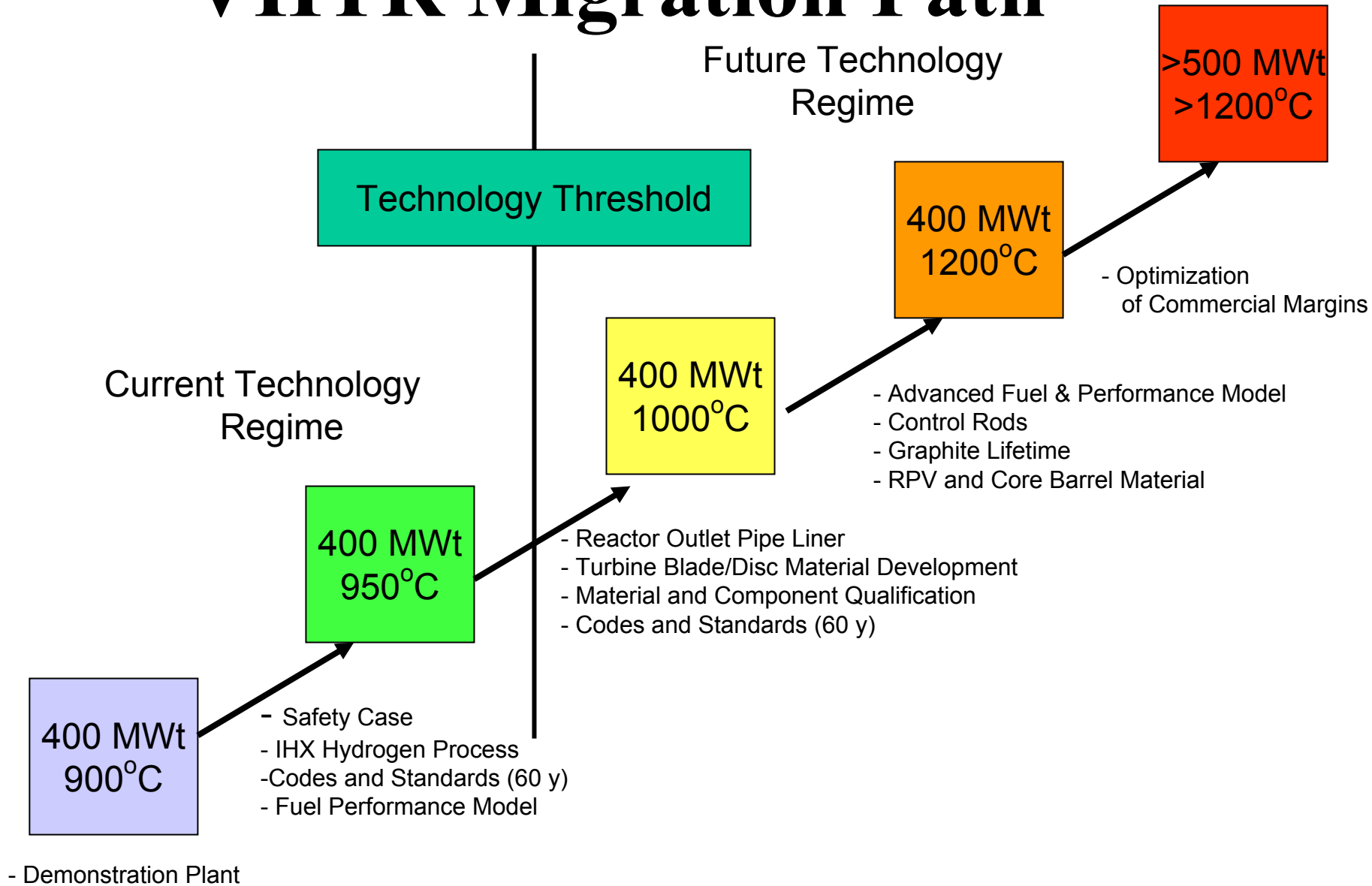

# Future Research Activities

- Build and Test Advanced Plate Fin IHX Design
- Benchmark new series of NACOK Air Ingress Tests with CFD.
- Perform Pebble Flow Experiments to Reduce Central Column By-pass Flow
- Expand Fuel Performance Model to handle rapid transients (rod ejection)
- Make and Test Advanced Fuel Particles with manufacturing and QA integration

# Summary

- Safety advantages of High Temperature Reactors are a significant advantage.
- Air ingress most challenging to address
- Fuel performance needs to be demonstrated in operational, transient and accident conditions.
- Validation of analysis codes is important
- Materials issues may limit maximum operating temperatures and lifetimes of some components.
- International cooperation is essential on key safety issues.

# End of Presentation

Back up Slides follow





# Summary

- High Temperature Reactors are a viable future nuclear option.
- NGNP to be the demonstration plant
- Research to lead to Gen IV VHTR for hydrogen production
- Small size an advantage to deployment and cost if manufacturing modularity approaches followed.

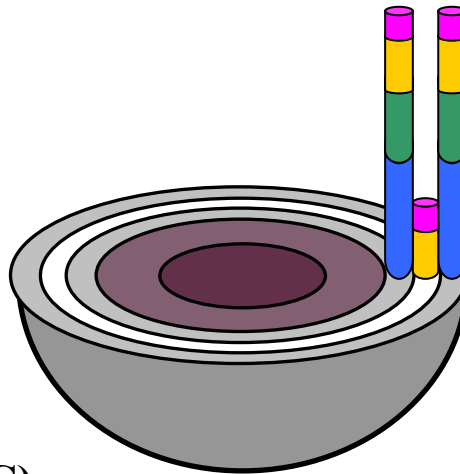
# Mechanical Analysis

- **System: IPyC/SiC/OPyC**
- **Methods: Analytical or Finite Element**
- **Viscoelastic Model**
- **Mechanical behavior**
  - irradiation-induced dimensional changes (PyC)
  - irradiation-induced creep (PyC)
  - pressurization from fission gases
  - thermal expansion



-  **Dimensional changes**
-  **Creep**
-  **Pressurization**
-  **Thermal expansion**

**Stress contributors to IPyC/SiC/OPyC**

# Integrated Fuel Performance Model

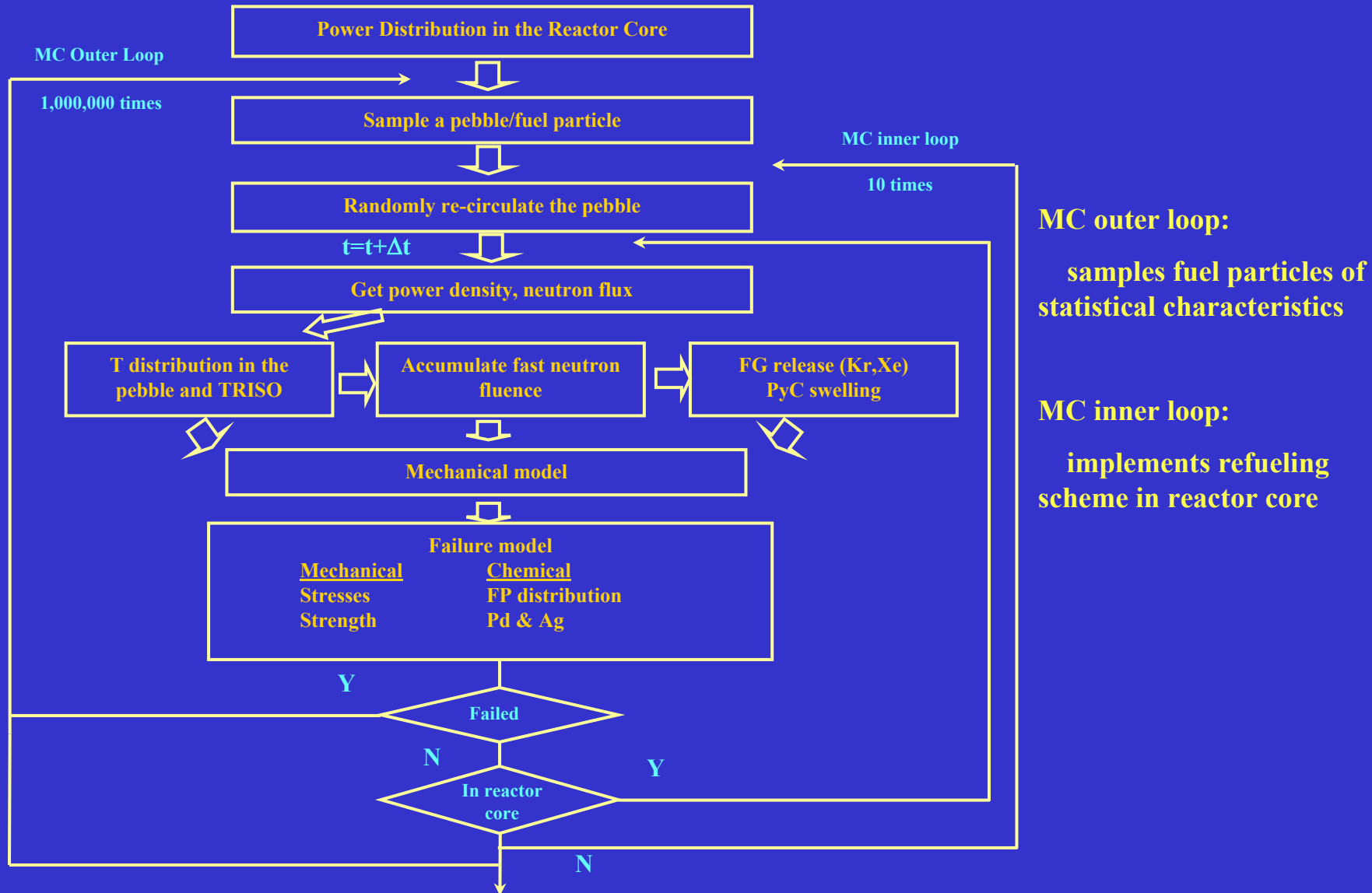

# Stress Contributors

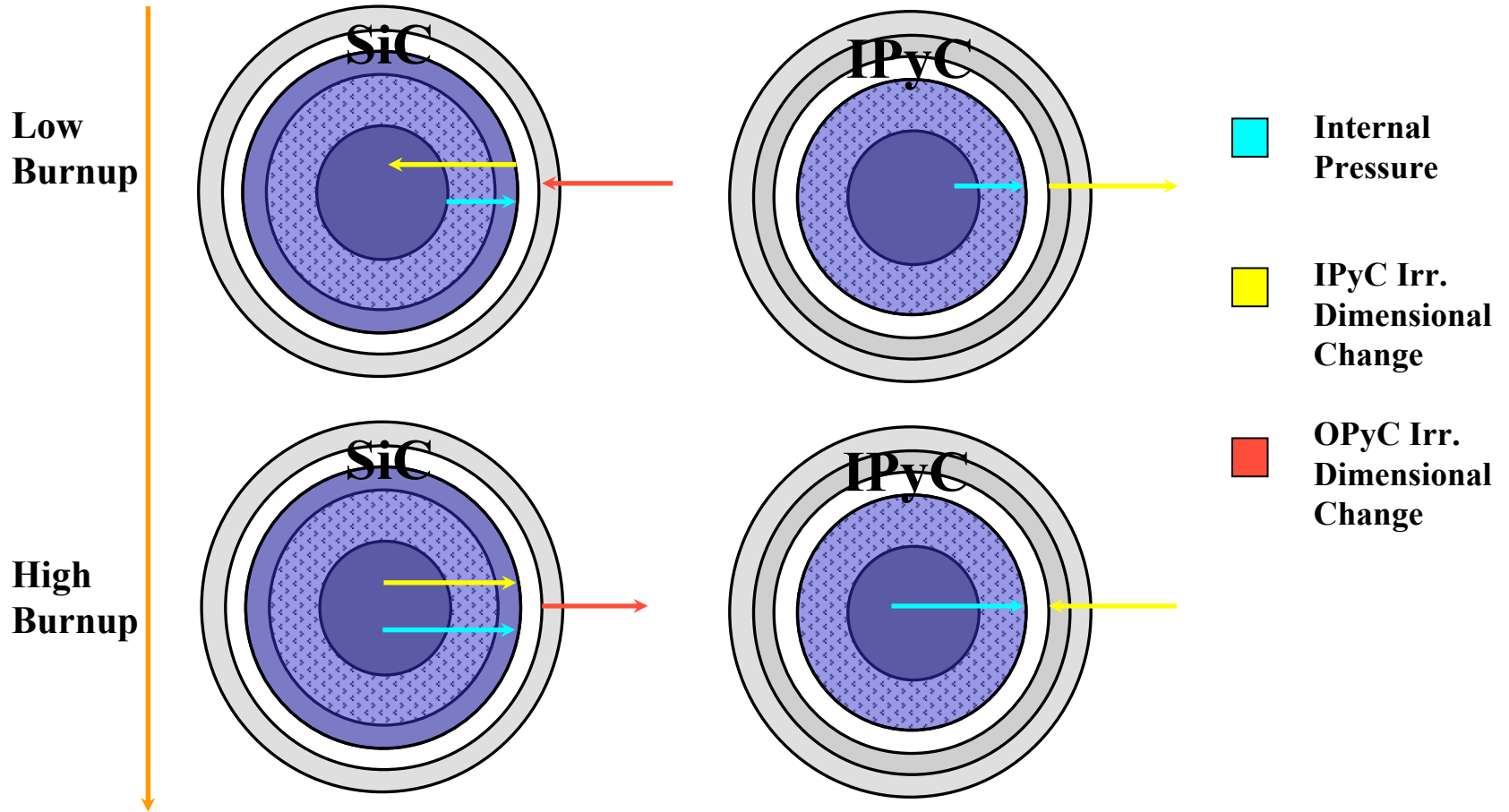

# TIMCOAT Failure Model (Simplified)

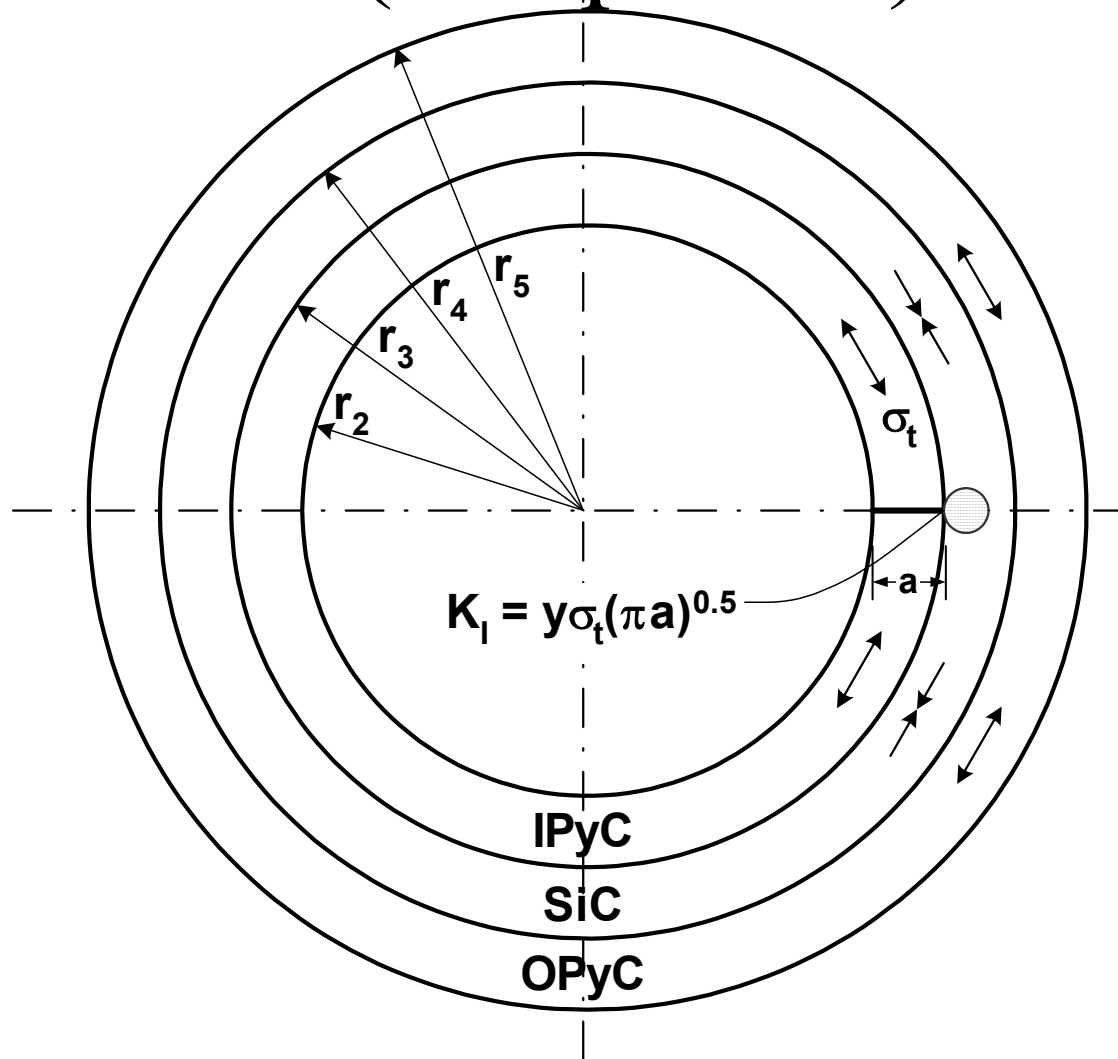

# Evaluate Stress Concentration in SiC

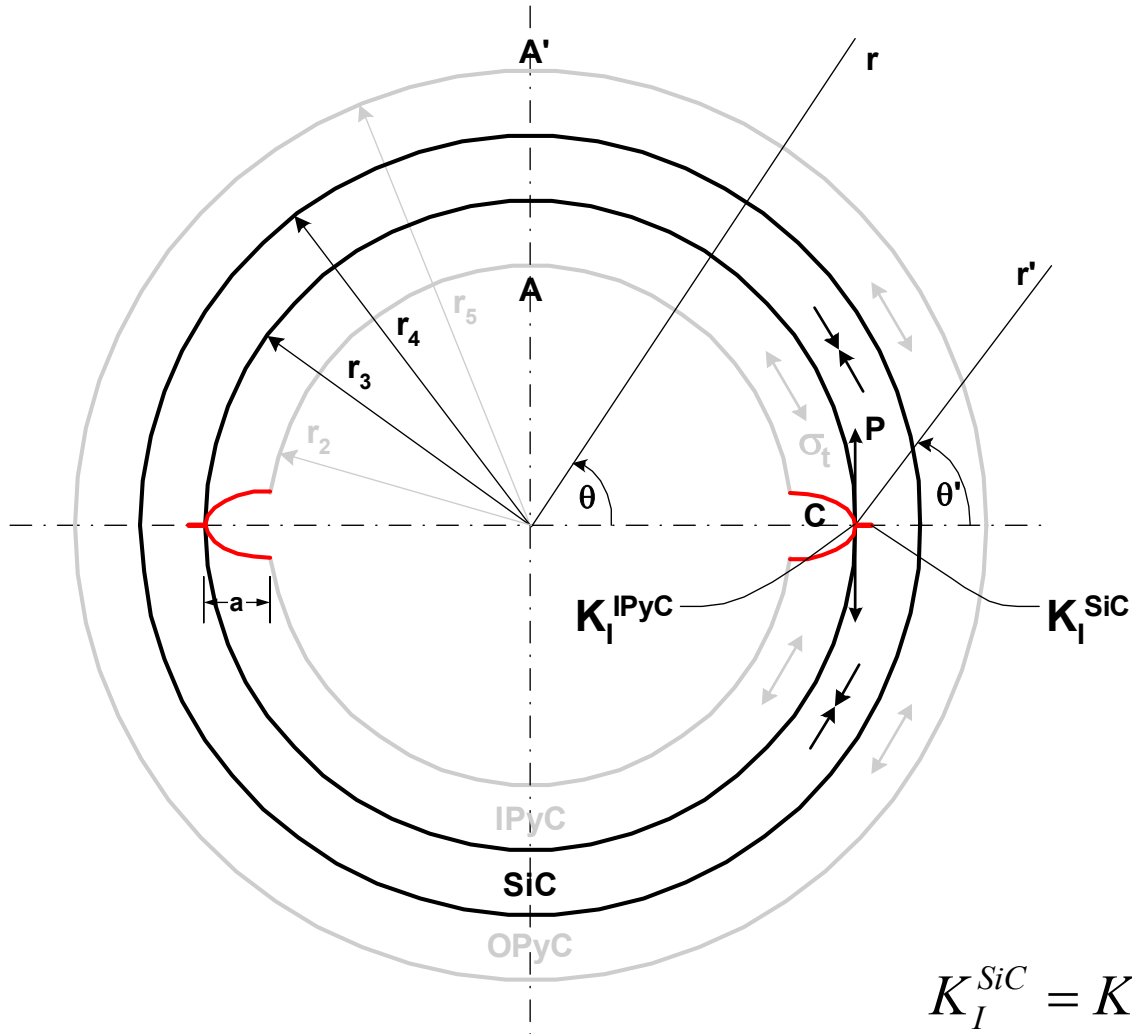

$$K_I^{SiC} = K_I^{IPyC} \sqrt{d / a_{IPyC}} + \bar{\sigma}_{SiC} \sqrt{\pi d}$$

# Modules in the Integrated Model

- **Fission gas release model**
- **Thermal model**
- **Mechanical analysis**
- **Chemical analysis**
- **Fuel failure model**
- **Simulation of refueling**
- **Optimization process**

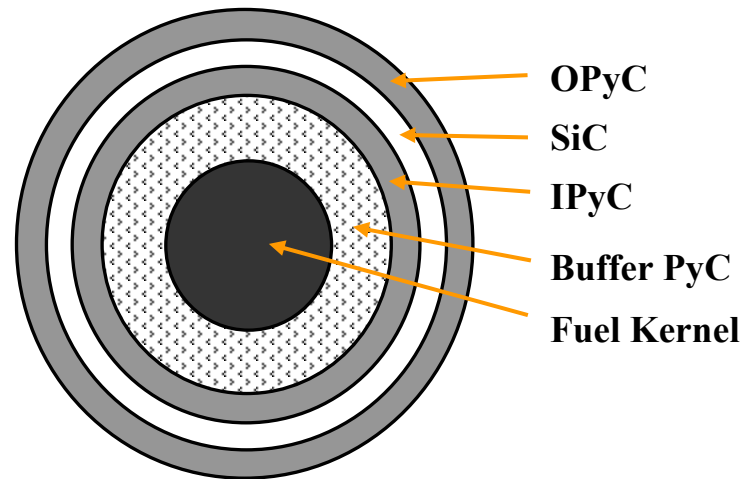

J. Wang, B. G. Ballinger, H. Maclean, "An Integrated Fuel Performance Model for Coated Particle Fuel",

# Stress Development in a Failed Particle

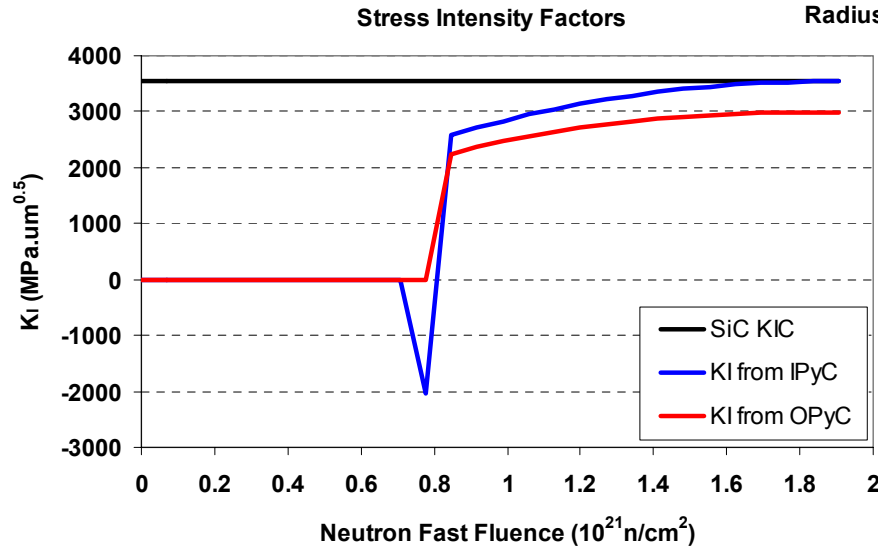
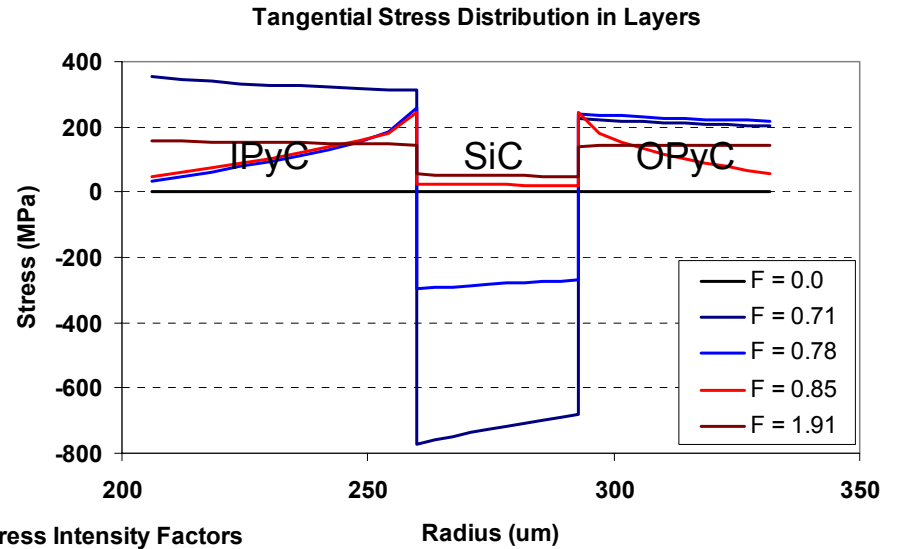
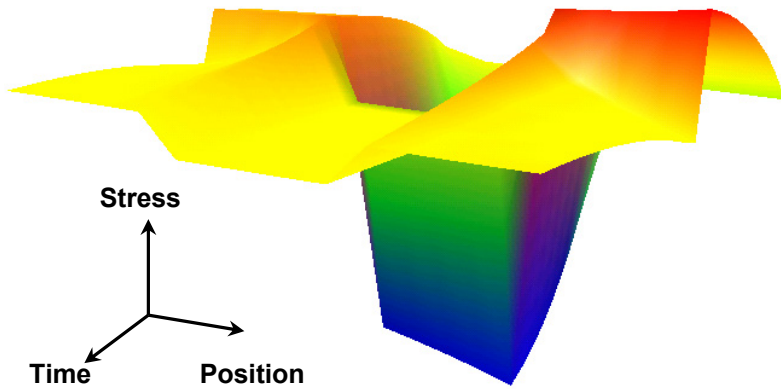

# Fuel Particle Types

Parameter	Design	As-Fabricated	Design Optimized <sup>a</sup>	As-Fabricated Optimize <sup>d</sup> <sup>b</sup>	Design Optimized (Widened BAF) <sup>c</sup>
U235 Enrichment (%)	9.6 +/- 0.1	9.6 +/- 0.1	9.6 +/- 0.1	9.6 +/- 0.1	9.6 +/- 0.1
Kernel Density (g/cm <sup>3</sup> )	10.4 +/- 0.01	10.4 +/- 0.01	10.4 +/- 0.01	10.4 +/- 0.01	10.4 +/- 0.01
Kernel Diameter (μm)	500 +/- 20.0	497 +/- 14.1	600 +/- 20.0	600 +/- 14.1	600 +/- 20.0
Buffer Density (g/cm <sup>3</sup> )	1.05 +/- 0.05	1.05 +/- 0.05	1.05 +/- 0.05	1.05 +/- 0.05	1.05 +/- 0.05
Buffer Thickness (μm)	90.0 +/- 18.0	94.0 +/- 10.3	120 +/- 18.0	120 +/- 10.3	120 +/- 18.0
IPyC Density (g/cm <sup>3</sup> )	1.90	1.90	1.99	1.99	1.99
IPyC Thickness (μm)	40.0 +/- 10.0	41.0 +/- 4.00	30.0 +/- 10.0	30.0 +/- 4.00	30.0 +/- 10.0
OPyC Density (g/cm <sup>3</sup> )	1.90	1.90	1.99	1.99	1.99
OPyC Thickness (μm)	40.0 +/- 10.0	40.0 +/- 2.20	70.0 +/- 10.0	70.0 +/- 2.20	70.0 +/- 10.0
IPyC/OPyC BAF0	1.058 +/- 0.00543	1.058 +/- 0.00543	1.08 +/- 0.00543	1.08 +/- 0.00543	1.08 +/- 0.00816
IPyC/OPyC Strength (MPa.m <sup>3/β</sup> )	23.6	23.6	27.8	27.8	27.8
IPyC/OPyC Weibull Modulus β	9.5	9.5	9.5	9.5	9.5
SiC Thickness (μm)	35.0 +/- 4.00	36.0 +/- 1.70	25.0 +/- 4.00	25.0 +/- 1.70	25.0 +/- 4.00
SiC Strength (MPa.m <sup>3/β</sup> )	9.64	9.64	9.64	9.64	9.64
SiC Weibull Modulus β	6.0	6.0	6.0	6.0	6.0
SiC Fracture Toughness (MPa.μm <sup>1/2</sup> )	3300 +/- 530.7	3300 +/- 530.7	3300 +/- 530.7	3300 +/- 530.7	3300 +/- 530.7

a: Optimized nominal values + Design Specified Standard Deviations

b: Optimized nominal values + As-fabricated Standard Deviations

c: Widened Standard Deviation of PyC BAF0 on “Case a”

# Fuel Optimization Results

- Environment
  - Given Irradiation Temperature: 910 °C
- Particle Dimension
  - Kernel Diameter (upper limit): 600μm
  - Buffer Thickness: 120μm
  - IPyC Thickness (lower limit): 30μm
  - SiC Thickness (lower limit): 25μm
  - OPyC Thickness (upper limit): 70μm
  - Whole particle radius: 545μm
- Material Properties
  - IPyC/OPyC Density: 1.99g/cm<sup>3</sup>
  - IPyC/OPyC BAF0: 1.08

# Silver Mass Loss

## SiC-1

graphite shell, standard SiC coating

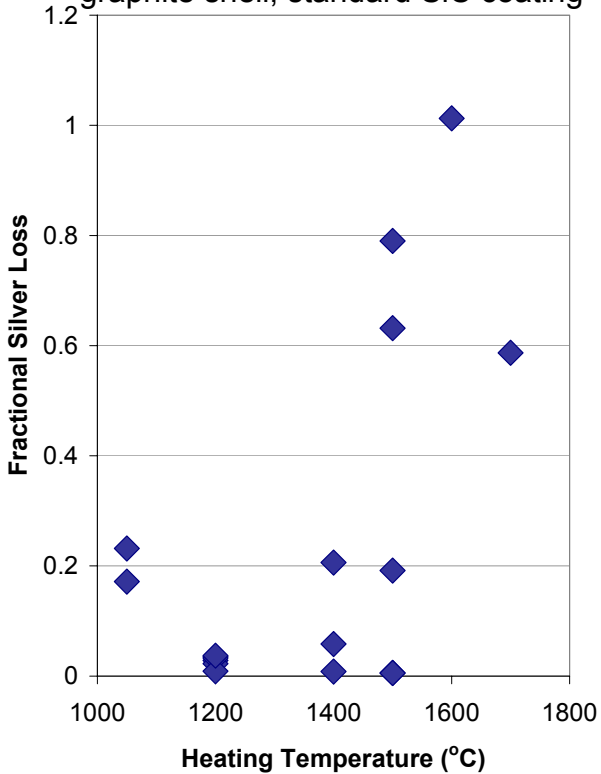

## SiC-2

graphite shell, modified SiC coating

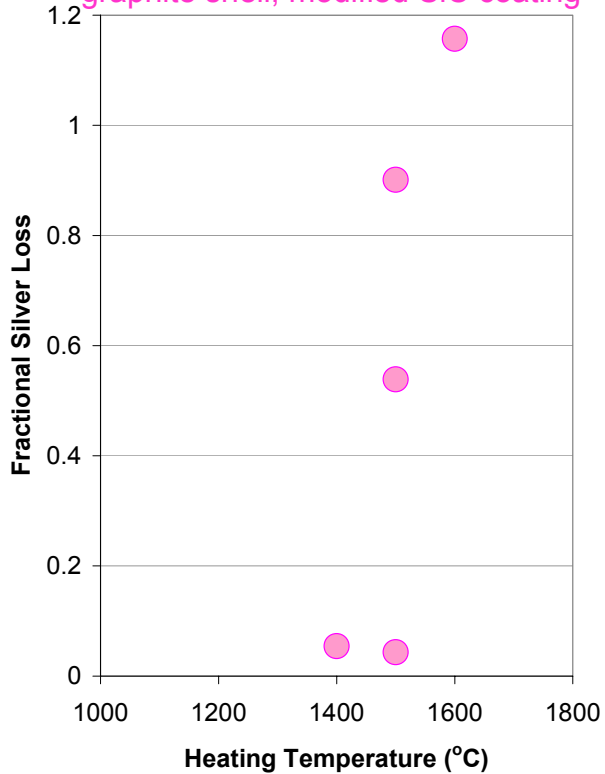

## SiC-3

SiC shell, standard SiC coating

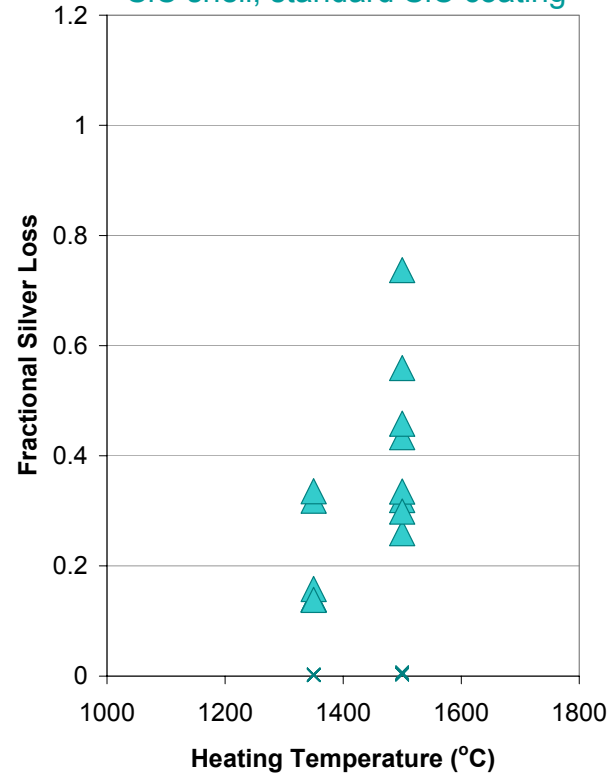

(normalized to seam area)

# Silver Ion Implantation

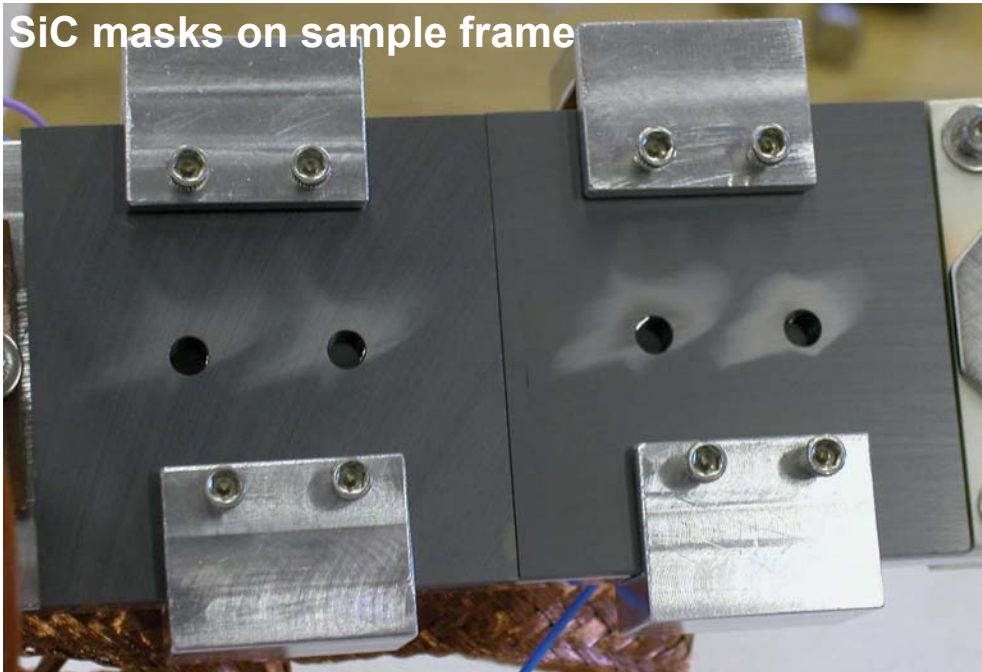

Light transmission through SiC mask and sample



- 161 MeV silver beam, peak at 13  $\mu\text{m}$
- 93 MeV silver beam, peak at 9  $\mu\text{m}$
- implanted  $\sim 10^{17}$  ions =  $\sim 2$  atomic % silver
- measure silver concentration profiles
- examine SiC damage



# Modeling Considerations

## *Packing of Spheres*

- Spheres dropped into a cylinder pack randomly
- Packing fraction  $\sim 0.61$
- Repeated-geometry feature in MCNP4B requires use of a regular lattice
- SC, BCC, FCC or HCP?
- BCC/BCT works well for loose sphere packing

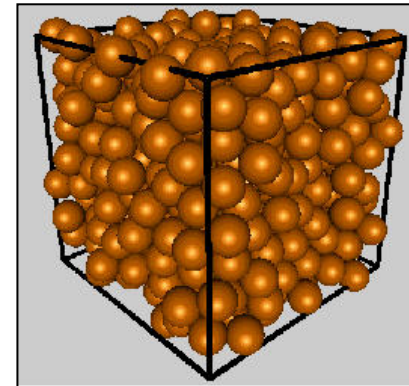

Random Close Packed

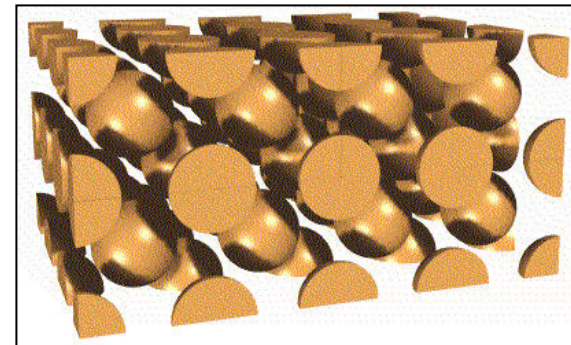

Body Centered Cubic



# HTR-10 MCNP4B Model

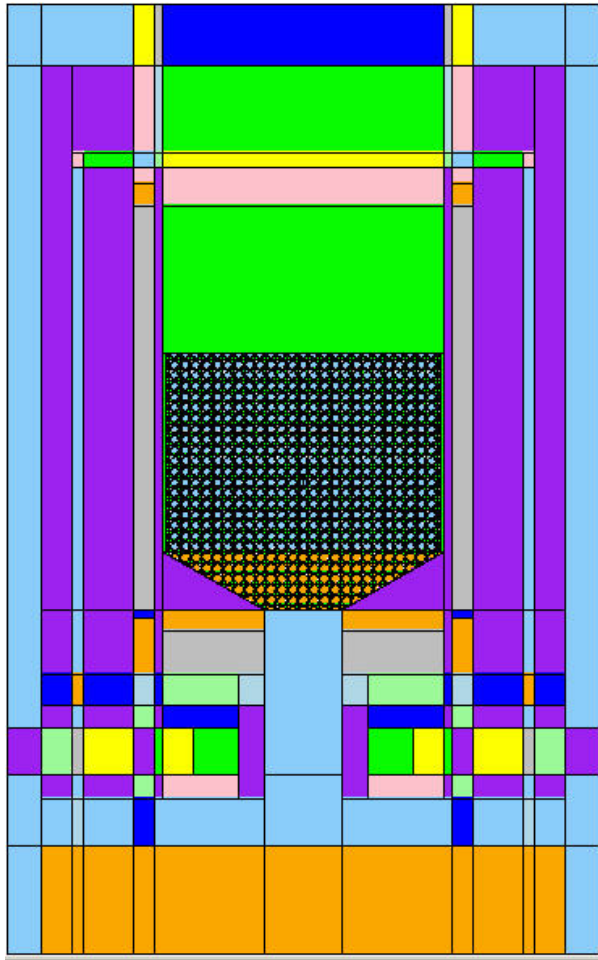

Reactor

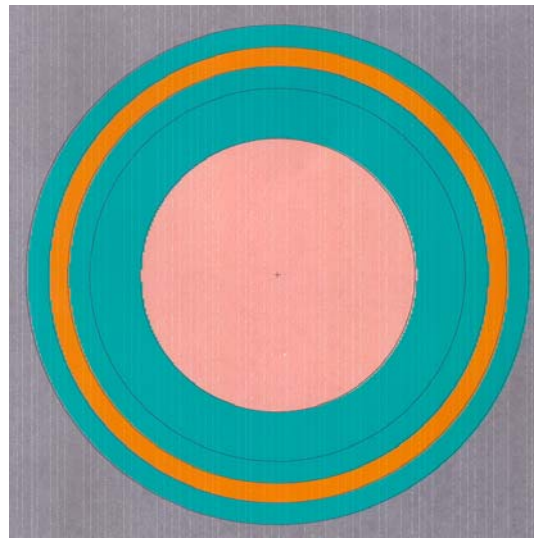

TRISO fuel particle

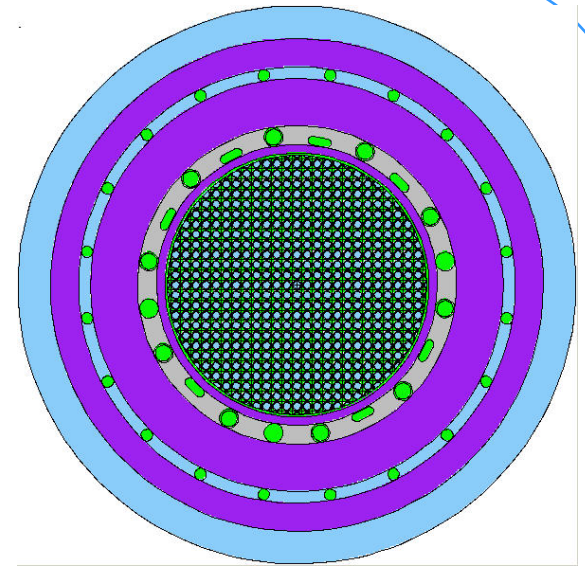

Core

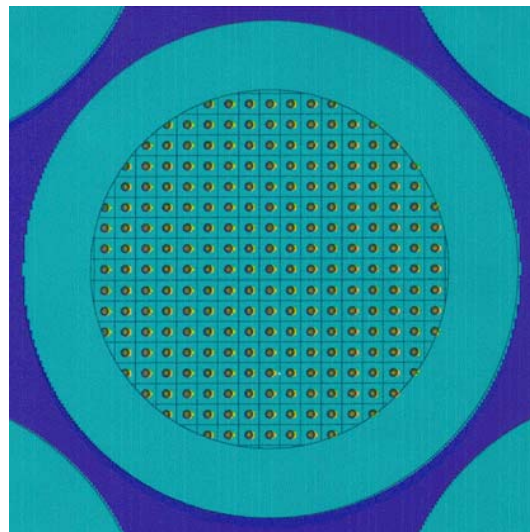

Fuel sphere

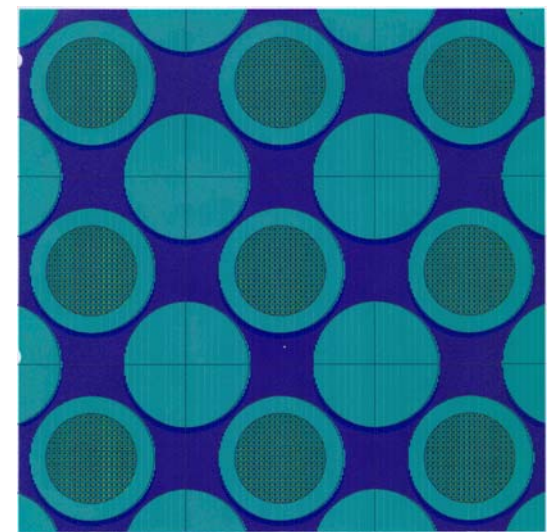

Core lattice





# IAEA Physics Benchmark Problem

## *MCNP4B Results*

B1	$h = 128.5 \text{ cm}$	critical height (300 K)
B20	$k = 1.12780 \pm 0.00079$	300 K UTX <sup>†</sup>
B21	$k = 1.12801$	293 K   UTX, no expansion
B22	$k = 1.12441$	393 K   (curve fit of k-eff @
B23	$k = 1.12000$	523 K   300 K, 450 K, 558 K)
B3	$k = 0.95787 \pm 0.00089$ $\Delta\rho \approx 157.3 \text{ mk}$ ( $\Delta\rho \approx 152.4 \text{ mk}$ )	300 K UTX total control rod worth INET VSOP prediction)

<sup>†</sup> Temperature dependent cross-section evaluation based on ENDF-B/VI nuclear data by U of Texas at Austin.

# Graphite Combustion

- **Robust, self-sustaining oxidation in the gas phase involving vaporized material mixing with oxygen**
- **Usually produces a visible flame.**
- **True burning of graphite should not be expected below 3500 °C. (From ORNL experiments)**

# Air Ingress Mitigation

- Air ingress mitigation strategies need to be developed
  - Realistic understanding of failures and repairs
  - Must be integrated with “containment” strategy to limit air ingress
  - Short and long term solution needed

# PBMR Design Maturity

- **Based on successful German pebble bed experience of AVR and THTR from 1967 to 1989**
- **Evolution of direct cycle starting with Eskom evaluations in 1993 for application to South Africa grid**
- **Over 2.7 million manhours of engineering to date with 450 equivalent full-time staff (including major subcontractors) working at this time**
- **Over 12,000 documents, including detailed P&IDs and an integrated 3D plant model**
- **Detailed Bill of Materials with over 20,000 line items and vendor quotes on all key engineered equipment**

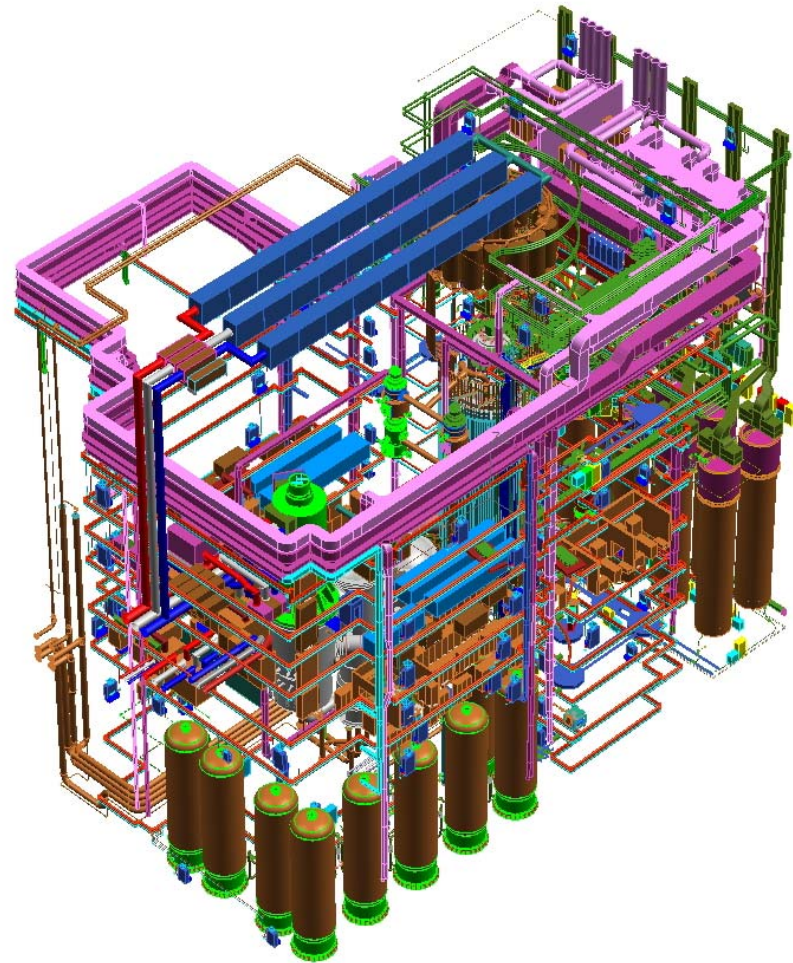



P B M R

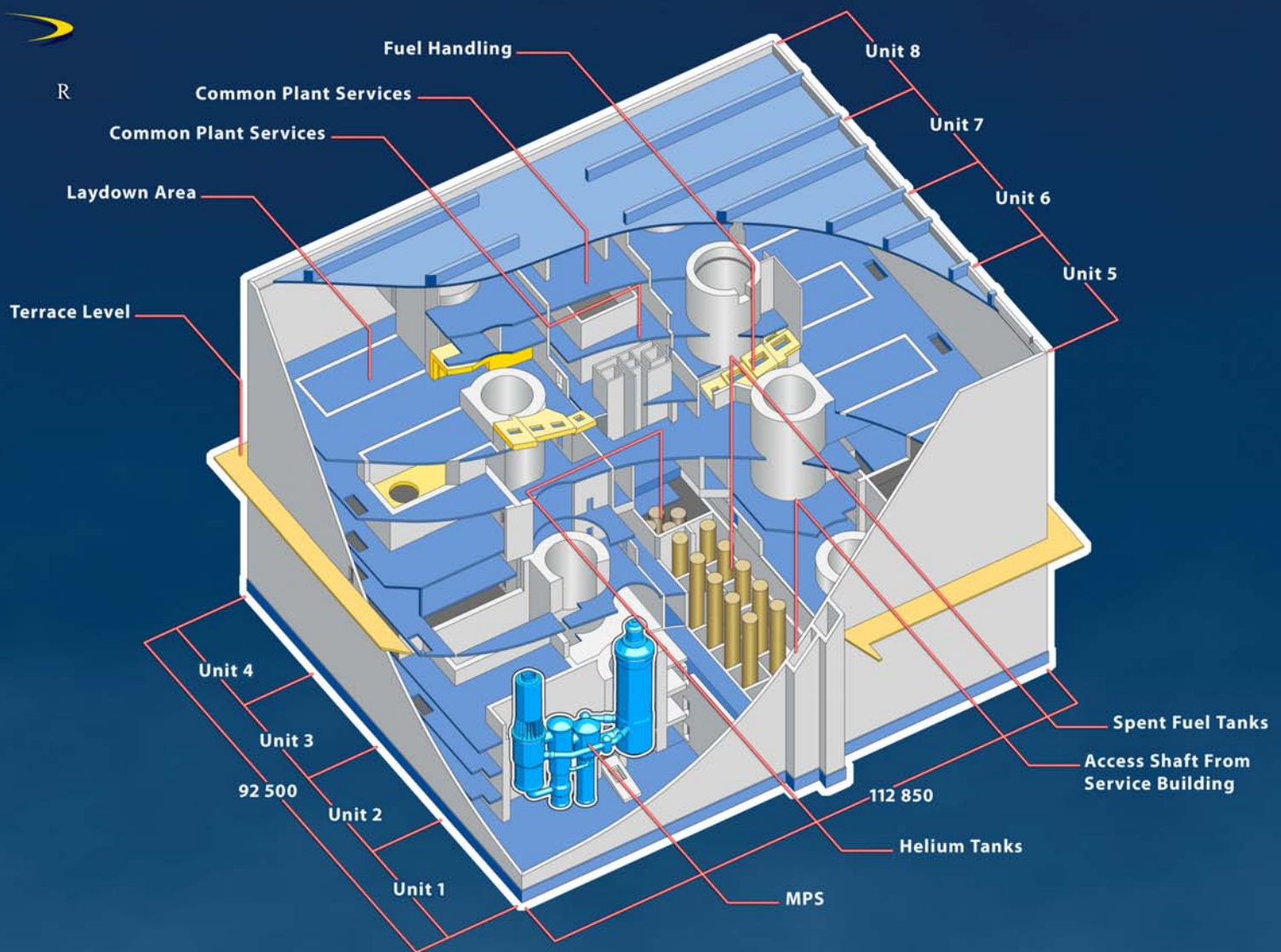

**Cut Away Isometric of PBMR Multi Module Concept**

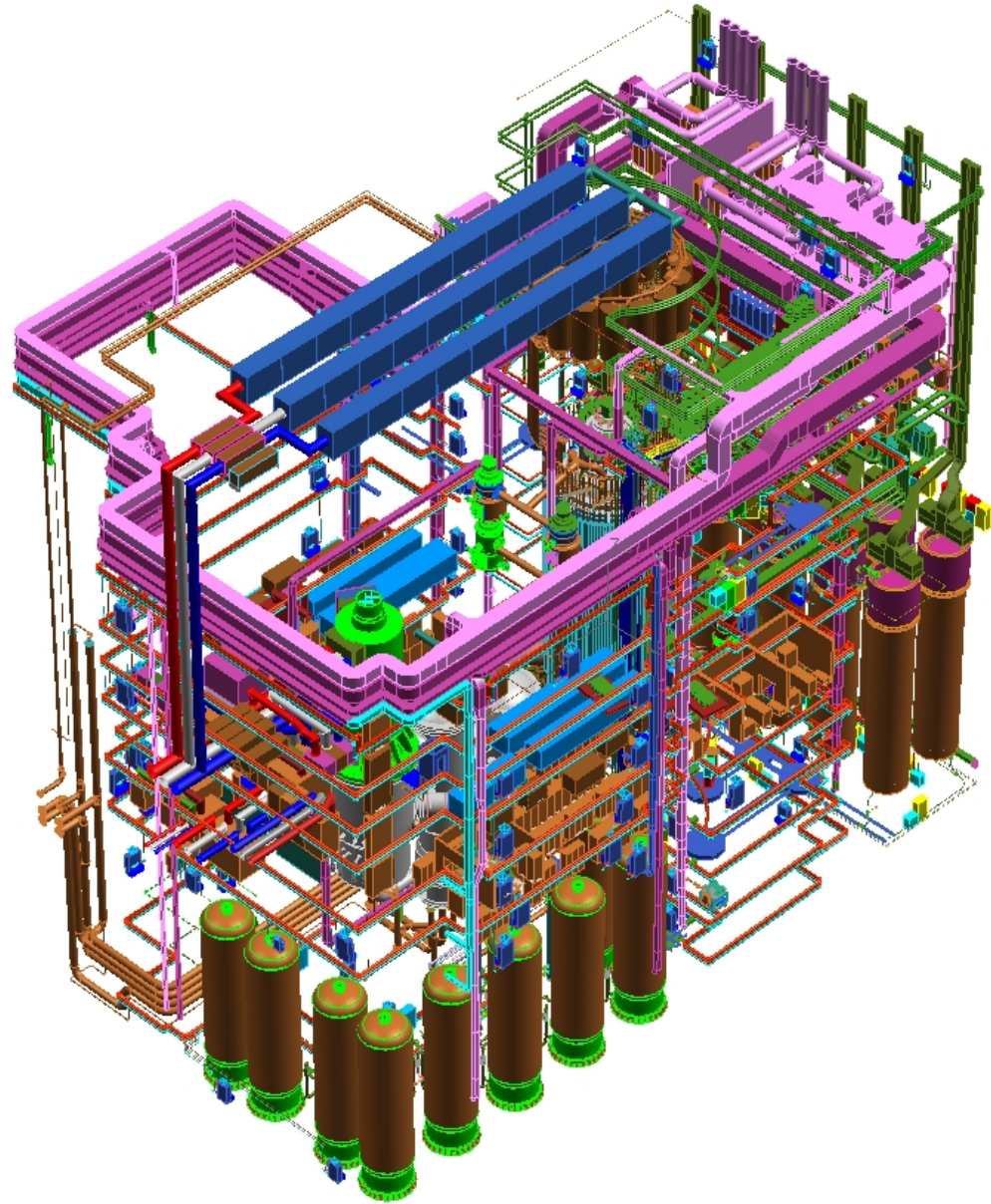

TOP WORK

# Integrated PBMR Program Plan

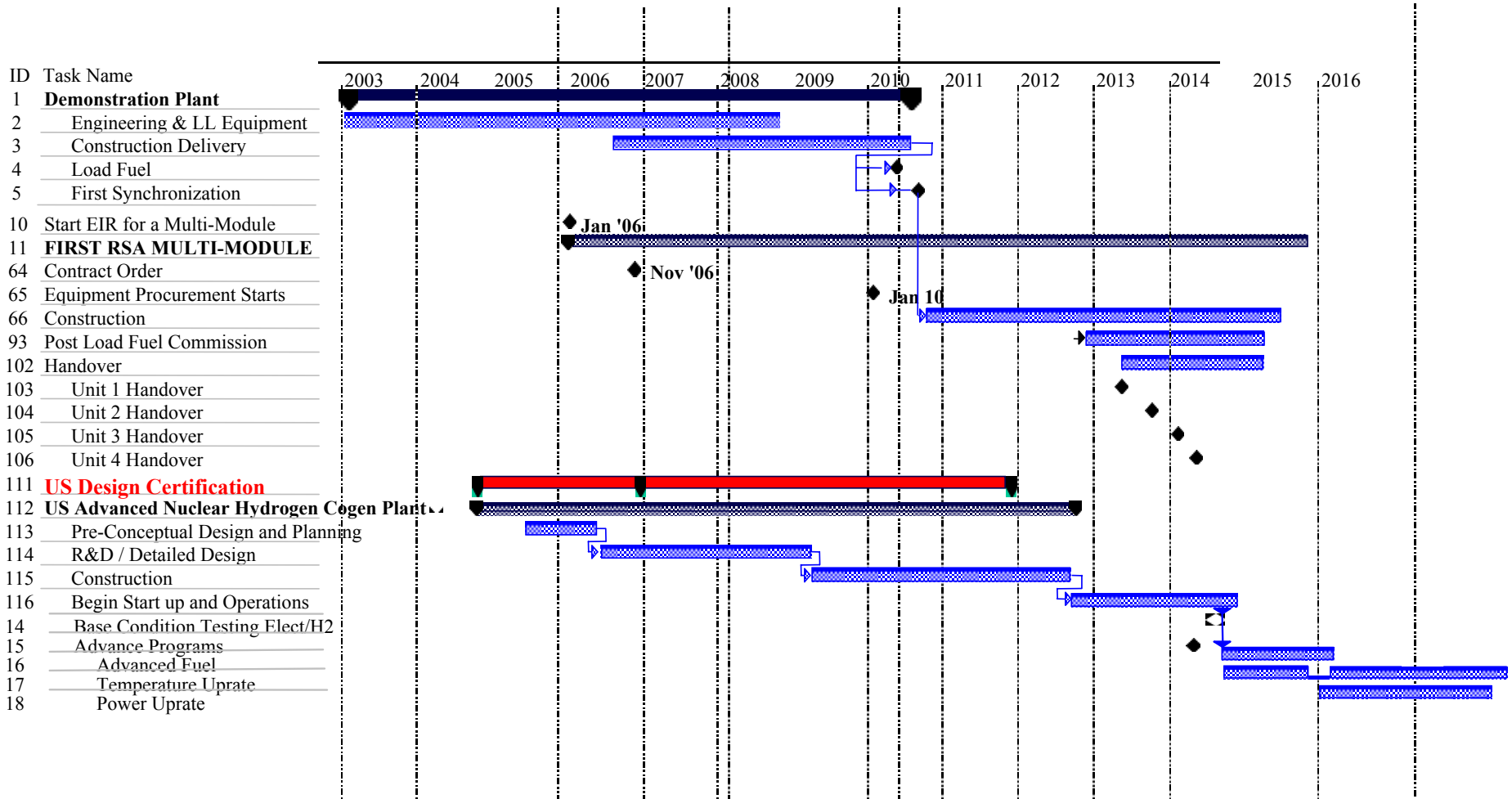

# Time schedule

	00	01	02	03	04	05	06	07	08	09	10
<b>HTR-10 criticality</b>	█										
<b>HTR-10 hot commissioning</b>		█	█	█							
<b>HTR-10 power operation</b>				█	█	█					
<b>HTR-10 safety experiments</b>				█	█	█					
<b>HTR-10 gas turbine cycle test</b>		█	█	█	█	█	█	█			
<b>HTR-PM feasibility study and design</b>		█	█	█	█	█	█	█			
<b>HTR-PM Construction</b>							█	█	█	█	█
<b>R&amp;D on hydrogen production</b>					█	█	█	█	█	█	█